

Incubator Series Configuration Table

COMEN

Configuration	B8 Infant Monitoring Incubator	B6 Infant Monitoring Incubator
Temperature (Incubator central temperatures and infant skin temperature)	✓	✓
Humidity in the incubator	✓	✓
Weight measurement	▲	▲
ECG		
NIBP		
Respiration	✓	▲
SpO ₂		
Pulse rate		
Arrhythmia analysis	▲	▲
ST Segment detection		
USB upgrade	✓	✓
EtCO ₂	▲	▲
O ₂ concentration monitoring		
Apnea monitoring	▲	▲
Apnea Self-saving monitoring		
Servo O ₂ supply		
Up-lifting	✓	✓
Camera	▲	▲
Recorder	▲	▲
Control mode	Air mode and infant mode	
> 37°C	Control through > 37°C button and screen interface	
Noise level	≤53dB	
Air flow rate	<0.1m/s	
Power-operated tilting of bed	-13° ~+13°	
Dimension	113cm (Length) × 68cm (Width) × 160cm (Height)	
Weight	120KG	
Rated power supply	100-250V~ 50/60Hz 6.6A	
Internal Battery	2200mAh, 14.8V rechargeable Lithium battery, more than 1 hour working time after fully charged (except from heating, Humidifying and lifting)	
Display	12.1" color touch screen Resolution: 800x600	

✓: Standard configuration ▲: Optional configuration



B8/B6 Infant Monitoring Incubator

When Incubator Encounters Monitor Love Drives Technology

Comen B8 Infant Incubator is a state-of-the-art neonatal environment that promotes natural, peaceful healing, while fostering a close bond between families and their babies—allowing them to be present for every step of the journey. In the past, incubator and patient monitor works separately, now COMEN integrated monitoring with nurturing. A more safety and effective incubator with powerful function, artistic outward appearance and easy operation is now introduced to the world. Additionally, physicians have improved access to their smallest patients, giving them a better chance at providing successful treatment, the very first time around.

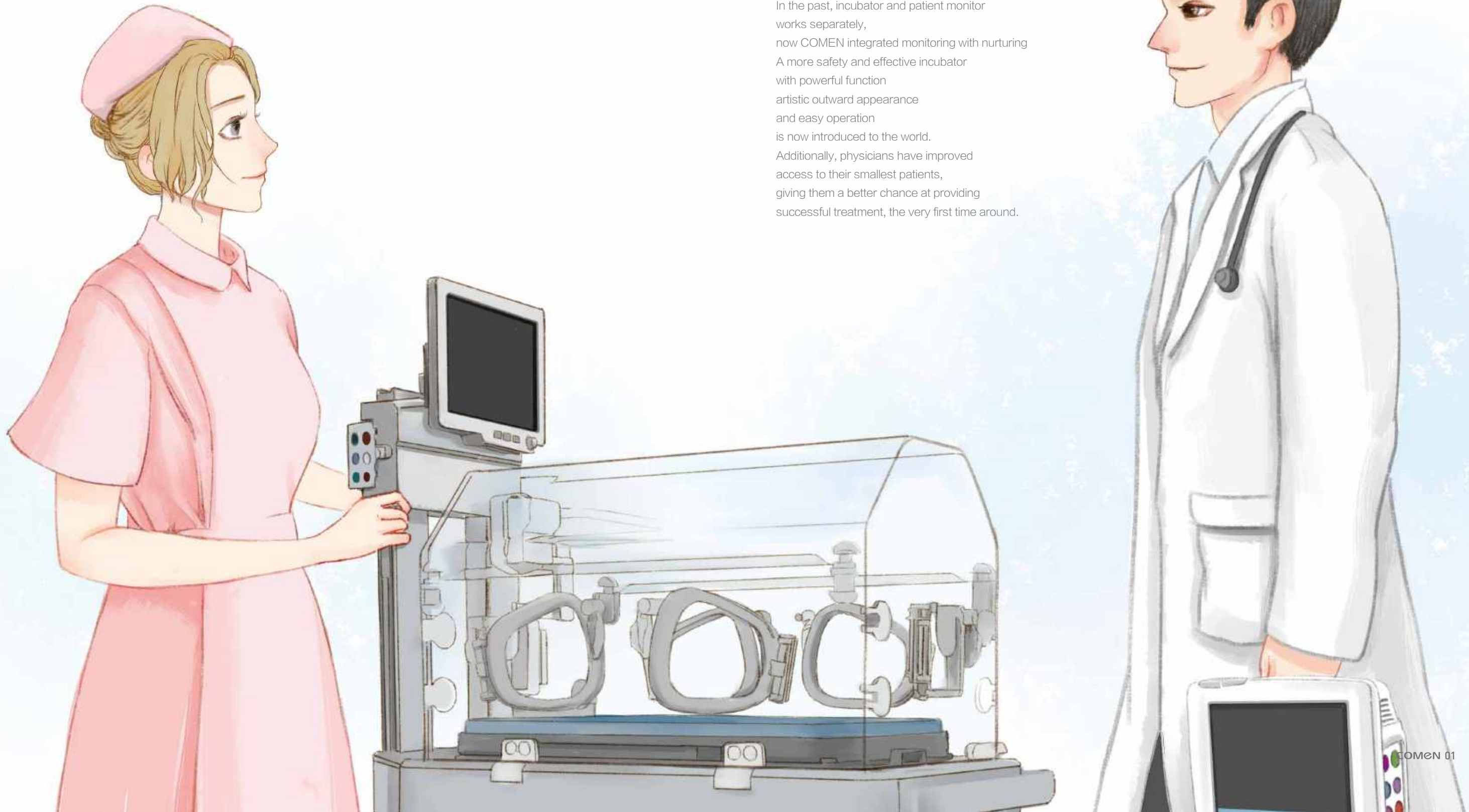

A Deeper Love

Neonatal incubator is warming equipment used for providing constant temperature and humidity for treatment of premature infants and critical neonates on the basis of satisfying their physiological characteristics and needs. COMEN B8 incubator was thoughtfully designed to provides stable temperature and suitable humidity ambient, in addition to configured vital signs monitoring function to promoting the growth and stability of even the most fragile of patients.

Incubator System

To research and develop one of the world's leading incubator, COMEN has always target top level products as its competitor. "Whatever the mind can conceive and believe you have the ability to achieve." Overcoming lots of difficulties and fighting for continuous 720days, COMEN B8 incubator provides stable temprature, suitable humidity and O₂ concentration to newborn in the whole journey.

temperature control technology

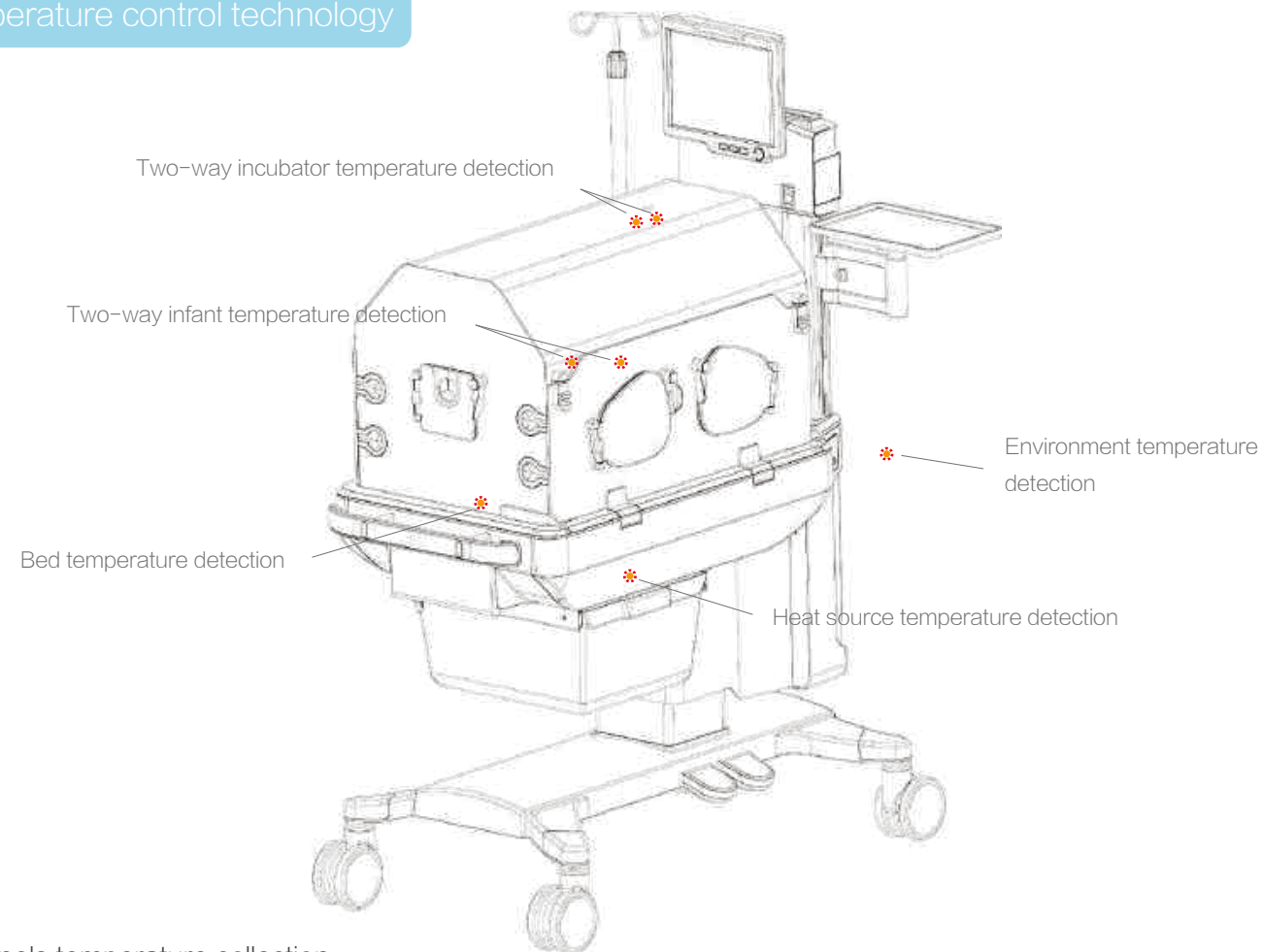

7 channels temperature collection:

Appropriate temperature inside the incubator can reduce neonates' loss of water and to reduce their risk of dehydration, B8 double guarantee the control of temperature through 7 channels of detection.

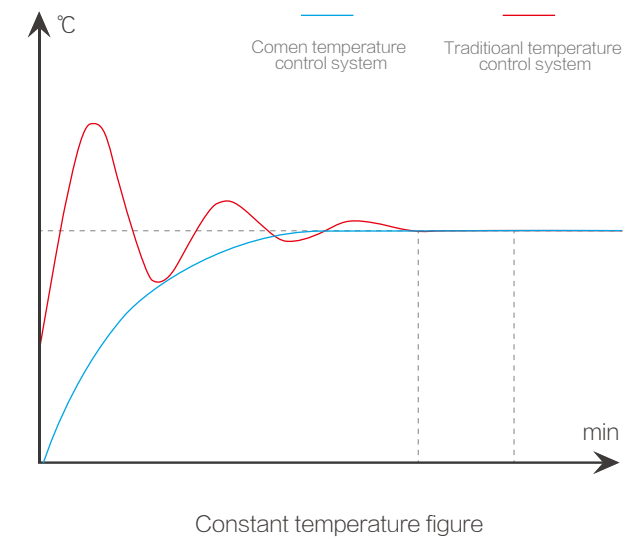

Intelligent Variable Resistance Heating Technology

Thanks to dual resistive heating tube and fin-style radiator, B8 shorten heating time of the incubator ≤ 30 mins with its control system, which saves time in emergency treatment of preterms, in addition, temperature fluctuation is significantly reduced to 0.3° .

Advanced air circulation: Dule inlet and out let Symmetrically

A more confortable environment with stable temprature and suitable humidity ambine is within reach.

3 independent over temperature protection:

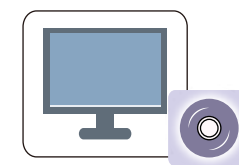

System protection

When temperature inside the shelf exceeds limits, heating instrument will stop heating automatically after detection by the control system



Hardware protection

A sensor is applied to control temperature through sending signals to heating instrument



Mechanical protection

A mechanical over temperature switch is used to prevent over temperature based on its high-temperature deformation characteristics

Humidity control technology

Thanks to PWM control technology and advanced humidity generator, the B8 infant incubator provides fast wetting speed so that an environment similar to mother's womb is created in a short period of time.

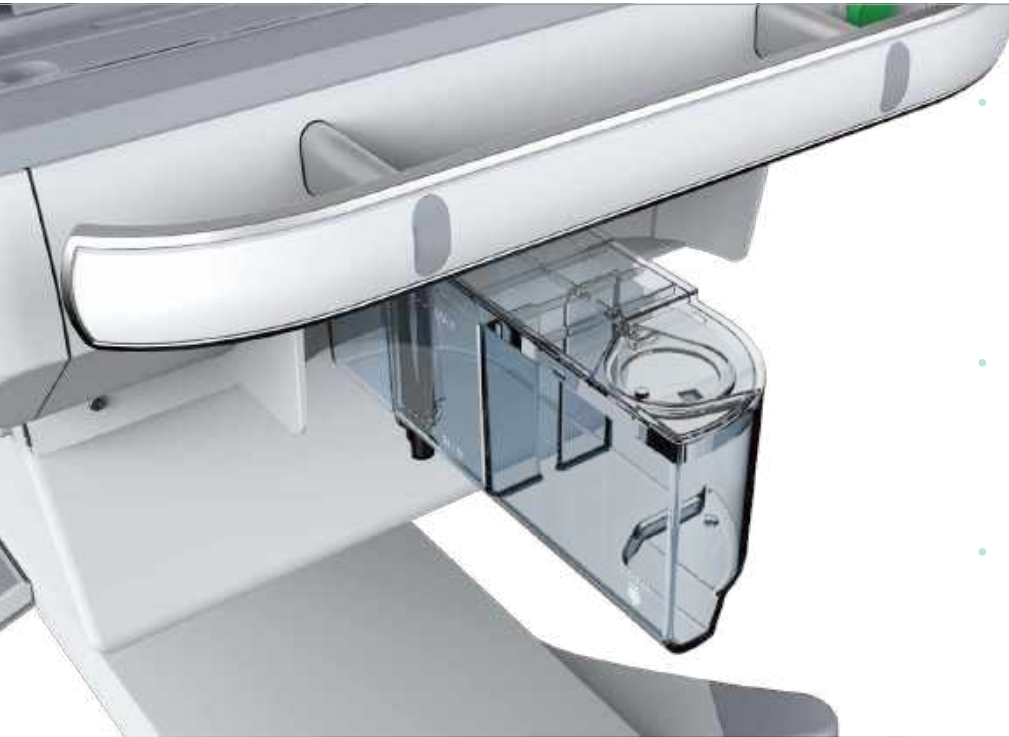
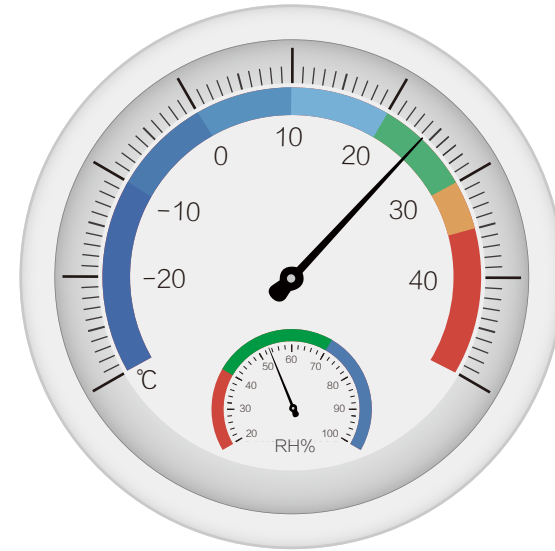

- Boiling sterilization: Disinfection and sterilization is through boiling water in the humidity generator. This humidification system is designed in accordance with earth gravity theory, so that water residue inside the generator could be avoided to get rid of bacteria breeding and contamination.
- Inner box wind speed control: $\leq 0.1\text{m/min}$, reduce the surface water loss of infants, lower the inner box noises and create a more quiet and comfortable environment.

Oxygen concentration control technology

- Servo Oxygen Supply: According to air-O₂ distribution standard and O₂ concentration adjustment, B8 infant incubator provides advanced close-loop feedback technology.
- One-press O₂ concentration calibration: Thanks to Comen patented technology—two-point calibration (21% and 100%), O₂ concentration detection precision reaches to $\pm 2\%$, higher than other brands.

Material

- The transparent shelf is made of food-level Perspex materials with high transparency, safety, and environmental friendly characteristics.
- The bed adopted nature color and environmental friendly ABS materials, more safe and more reliable, improving comfort.



Rolling castor from STEINCO with 86 years experiences in this industry, the provider of world famous manufacture such as Mercedes Benz, BMW.

Specialized Neonatal Monitoring System

Specialized Neonatal Monitoring System is a tailored system that created for NICU by COMEN, including ExNeo® ECG technology, Adap-DSP® self-adapt NIBP technology, Masimo SPO₂, Apnea self-rescue technology, and oxygen concentration detection function. And it is equipped with biocompatible specialized neonatal accessories. It not only ensures the correctness of ECG collection and NIBP measurement, but also solves the problem of neonatal respiratory distress syndrome, this system was used in the world first specialized neonatal monitor-COMEN C60.



Parameters / Monitoring object	Neonates (general)	Adults (general)
Heart rate	120 -160bpm Weak signal, High frequency	60 -100bpm Strong signal, low frequency
Respiration	40-50/ min	16-20/ min
NIBP	Systolic pressure : 70 - 82mmHg Diastolic pressure : 30 - 38mmHg Low PR	Systolic pressure : 90 -140mmHg Diastolic pressure : 60 - 90mmHg High PR
SpO ₂	Arterial peripheral blood perfusion 0.03% - 2%	Arterial peripheral blood perfusion 3%- 5%



ExNeo® Neonate ECG Measurement Technique

Due to the big difference between ECG signal of neonates and adults, ECG measurement technology has long been a difficult problem faced with neonatal monitoring workers, in addition, newborns' crying and struggling during ECG testing make this issue even worse. So it is difficult for traditional monitor to provide accurate ECG measurement data for neonates. Based on the feature that neonates' fast heart rate change, ExNeo® ECG measurement technique focus on improving ECG signal acquisition sensitivity and signal resolution ratio to get rid of neonates moving interference at the utmost, so that to guarantee ECG measurement accuracy and breathing rate test accuracy.

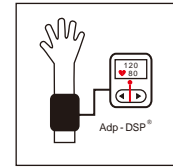

Adap-DSP® Adaptive Signal Processing Technology

According to the low blood pressure and weak perfusion character of neonate, Comen use Adap-DSP® system to provide more accurate blood pressure measurement. We all know that newborns are the most vulnerable lives, a small mistake during measurement would cause serious harm to them. Designed With unique neonate specialized measurement mode, Comen's neonatal monitor is able to completely eliminate the potential risk of failure operation.

Both software and hardware accessories are designed with over-pressure protection and the maximum pressure of NIBP cuff shall be no more than 150mmHg to guarantee newborns' safety. Comen's neonatal monitor improves its anti-interference performance of BP measurement to reduce influence of newborns' frequently movement. so no matter the newborns are moving or not, the monitor is able to guarantee its test accuracy.



Masimo SET Neonate SpO₂ Technique

People has made lots of trails in improving the detection sensitivity of pulse and SpO₂ value of neonates on the condition that their blood perfusion and cardiac output are extremely lower. The standard perfusion technology developed by Massimo is able to read at least 1/10 lower of blood perfusion than traditional pulse oximeter. Massimo SET performance on anti-interference is also outstanding. At present, the majority of NICU rooms have equipped with two or three high-end Massimo's SPO₂ monitor to meet their need of critically ill patients. Equipped with all kinds of clip and probes, it is suitable for babies of different size.

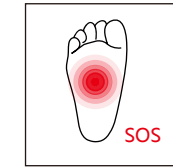

Apnea self-saving Monitoring

Apnea is the most common symptom of the newborns, and also a serious problem in NICU room. If not treated in time, it will cause the neonates oxygen-starved for long time, which may cause brain damage of the neonates and have great impact on their mental development. What's worse, it can cause neonates death under serious situation. Apnea self-saving monitoring can monitor newborns breathing in various ways and stimulate the nurse to flap their arch to arouse their breath.



Neonatal ECG Cable And Electrodes

Neonatal ECG cable and electrodes have passed biological compatibility.



Neonatal Monitor Protection

Various specification of neonates NIBP cuffs to guarantee measurement accuracy of different size of newborns



Masimo SpO₂

Use Masimo SpO₂ technology, Specialized neonatal suffocation self-saving function equipped with oxygen density monitoring function.



Apnea Self-rescue Probe

B8 has a probe that wrapped under the infant's foot to stimulate neonates to resume breathing. Abdomen attached respiration sensor : Neonates conduct abdominal breathing. Attach the sensor to the abdomen, obvious abdomen up and down movements squeeze the sensor and transforms respiratory signals to electric ones for the system to collect and identify.

Give Wings to the Parents Love



Worrying with anxiety, exhortation with care, looking with impatience, and leaving with reluctance are commonly seen outside of patient rooms. The best wishes of parents are stay 24 hours a day with their child. In order to avoid bacterial contamination, and to prevent frequent interruption of doctors' work, doctors have to implement the traditional visit system. COMEN builds a bridge between babies and parents with love, to alleviate their tension and anxiety, to realize real-time observation even away from the baby.



Traditional visiting:
Parents have to wait for long time to see their baby in the Department.



Remote Visiting System:
B8 support remote visiting function, parents can see their baby through an APP on their PC, handset/Ipad.



Spot Check System:
Doctors could turn on/off observation function freely, and it also has video clip, video playback functions to retain valuable evidences and cases.

Ingenuity Serves for Benevolence, All for Love

Ingenuity is shining at every part of its body. Thinking in a way that healthcare providers think, to help healthcare provider to reduce their workload, to improve the effectiveness of their treatment, to avoid operational risks, is the mission of us.

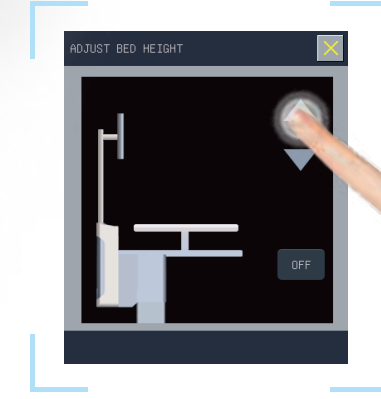

Electric Lift

Auto up-lifting of the incubator .
Pedal and touch screen dual operation.

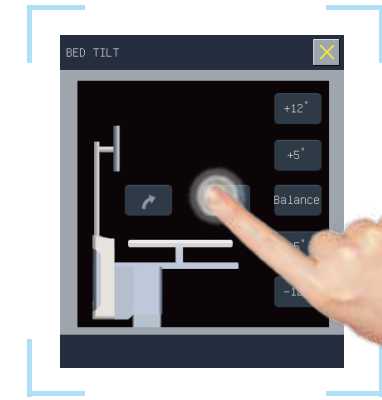

Intelligent Adjustment

Bed tilted angle support maximum 13° , touch screen control, intuitive operation.
Support one press “flat, 5° , 12° ” angle adjustment, to realize instant operation, saving time for clinical emergency, and nursing operation.





Unarmed disassemble of beds and sink to realize through cleaning and disinfection. The air circulation system can be thoroughly cleaned without removing the temperature control system and the heating equipment.



Human-Machine interaction

12.1 inches LED touch-screen, key board with backlit and touch operation, Screen angel adjustable, easy for observation.

Four independent CPU

Four independent CPU system, these are human-machine interaction, alarm system, temperature collection and thermoregulation, each system works independently without interference to each other, when one CPU fails, it won't affect other CPU systems.

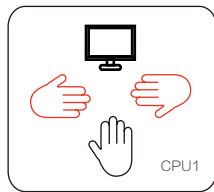

Human-machine interaction



Alarm system

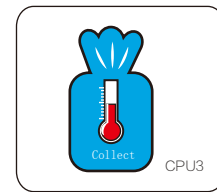

Temperature collection

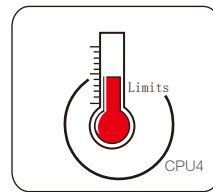

Thermoregulation

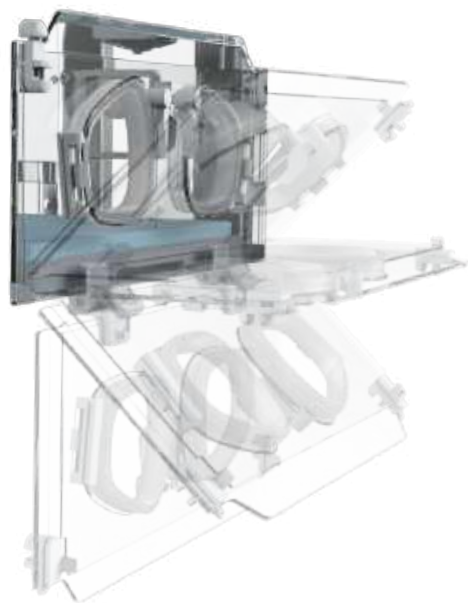

Integrated design of monitor and incubator:

- easy to manage equipments . Integrated design is able to avoid risk of monitor falling off.
- Neonatal specialized monitoring to avoid mistake operation of the monitor.
- The true realization of the integrated transport monitor and incubator.

Adopting damping design on the left and right access panel, easy to open and close. Slowly falling of the panel is able to get rid of hitting the incubator, creating a calm zone around the neonates.

Patient Case Management

Built-in 50mm thermal recorder, information such as vital parameters and incubator environment could be recorded.

Wards rounding / Remote Visiting System:

B8 support remote visiting and wards rounding function through internet with an APP on PC, handset/lpad.

APP



Wired/wireless central monitoring system, automatic save and record infants' vital parameter and incubator parameters.



Love Protects Babies Health Love Accompanies Babies Growth

Comen constantly integrates creative technology to the design and development of products, it developed from a simple manufacturer of medical devices to a provider of comprehensive medical solution, and developed a new generation of neonatal monitoring system for NICU solution. COMEN never stop in the path of protecting human health.

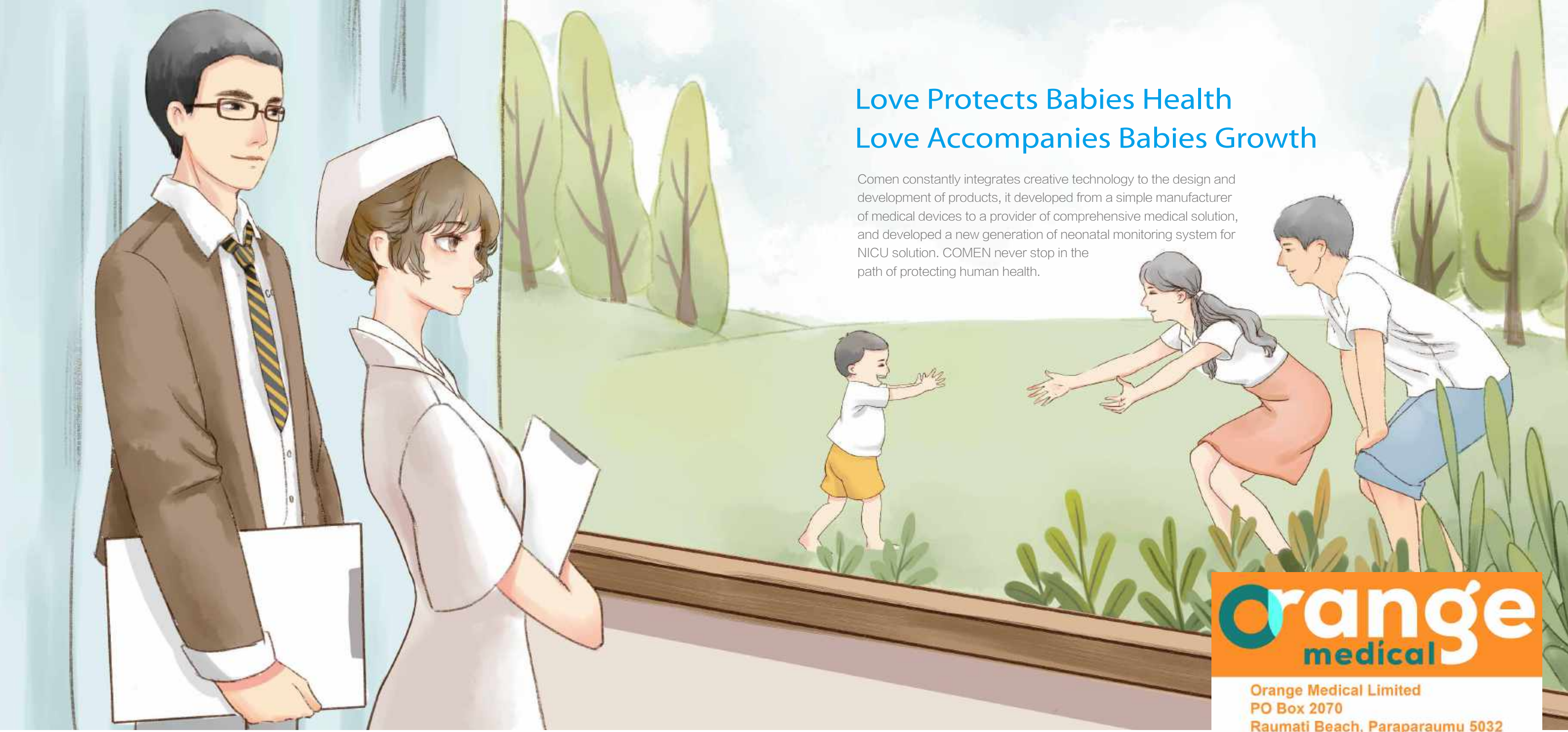

Orange Medical Limited
 PO Box 2070
 Raumati Beach, Paraparaumu 5032
 Phone: 0800 990024
 Email: sales@orangenz.co.nz
 www.orangenz.co.nz

NICU Comprehensive Solution

Based on the advantage of monitoring field, COMEN now has the first specialized neonatal monitor in the world, neonatal non-invasive ventilator with integrated non-invasive ventilation solution, all in one radiant rescue station, ceiling beam/pendant, air-oxygen blender, bubble CPAP, infusion workstation etc., to create the most professional NICU comprehensive solution.



B8 Infant Monitoring Incubator



NV8 Neonatal Ventilator



C60 Neonatal Monitor



D9 Ceiling Beam system



BQ80 Infant Radiant Warmer



M200 Infusion Workstation



KL20 Blender



Percutaneous Jaundice Device
(Not in the market yet)