

COMEN



B3 Infant Incubator

Orange Medical Limited
PO Box 2070
Raumati Beach, Paraparaumu 5032
Phone: 0800 990024
Email: sales@orangenz.co.nz
www.orangenz.co.nz

Incubator System

Neonatal incubator is warming equipment used for providing constant temperature and humidity for treatment of premature infants and critical neonates on the basis of satisfying their physiological characteristics and needs.

COMEN B3 incubator was thoughtfully designed to provides stable temperature and suitable humidity ambient, in addition to configure vital signs monitoring function to promoting the growth and stability of even the most fragile of patients.

temperature control technology

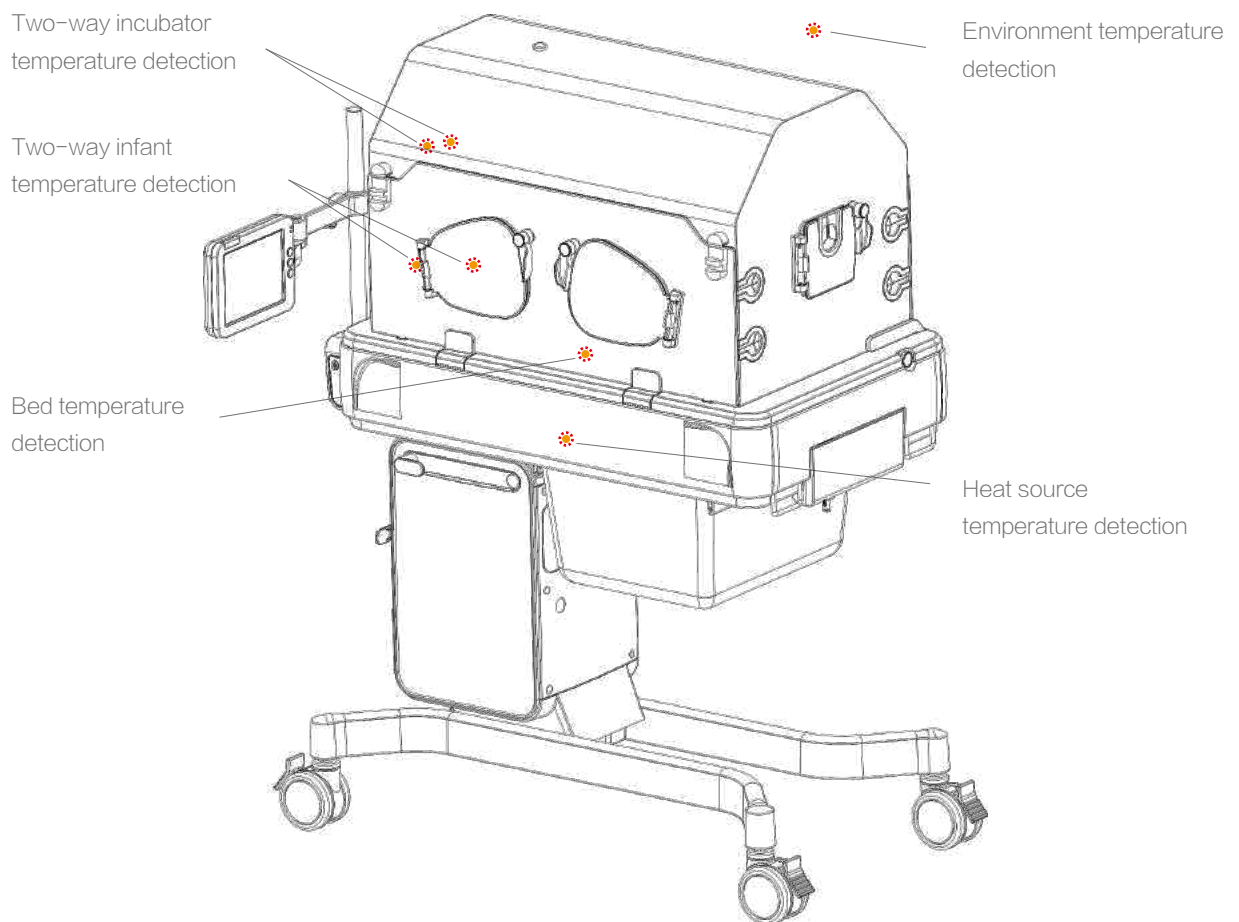

7 channels temperature collection:

Appropriate temperature inside the incubator can reduce neonates' loss of water and to reduce their risk of dehydration, B3 double guarantee the control of temperature through 7 channels of detection.

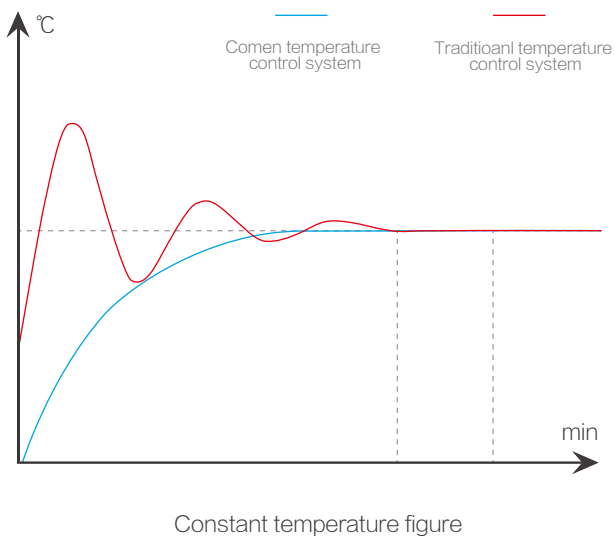

Intelligent Variable Resistance Heating Technology

Thanks to dual resistive heating tube and fin-style radiator, B3 shorten heating time of the incubator ≤ 30 mins with its control system, which saves time in emergency treatment of pretrms, in addition, temperature fluctuation is significantly reduced to 0.3° .

Advanced air circulation: Dule inlet and out let symmetrically

A more confortable environment with stable temperature and suitable humidity ambine is within reach.

3 independent over temperature protection :

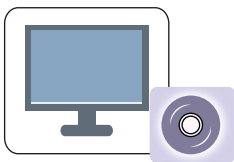

System protection

When temperature inside the shelf exceeds limits, heating instrument will stop heating automatically after detection by the control system



Hardware protection

A sensor is applied to control temperature through sending signals to heating instrument



Mechanical protection

A mechanical over temperature switch is used to prevent over temperature based on its high-temperature deformation characteristics

Humidity control technology

With PWM control technology and highly-effective humidity generator, B3 provide rapid wetting to create an environment that more close to maternal for neonates leep comfortably.

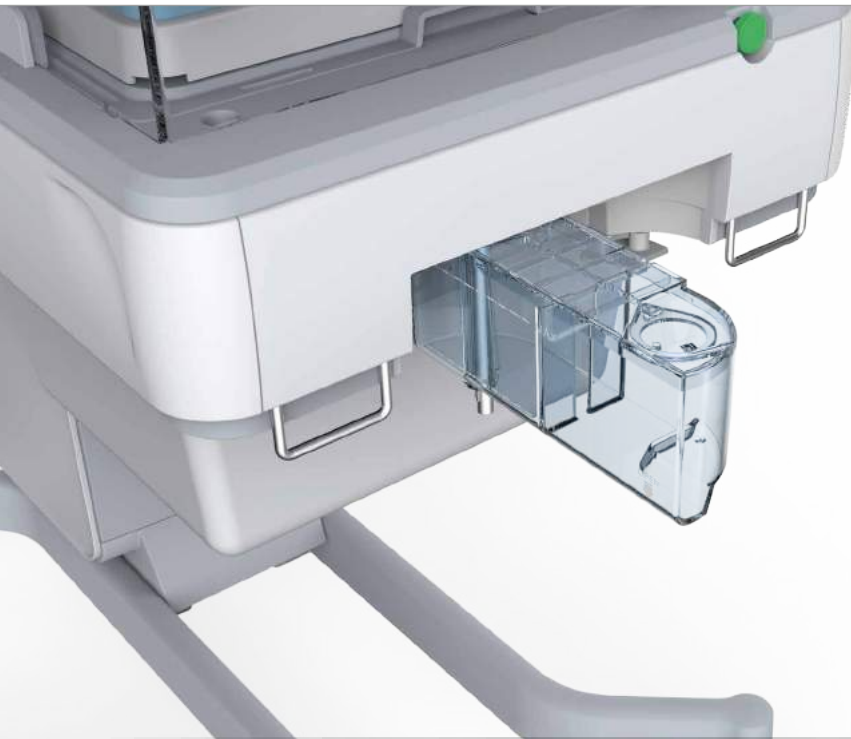
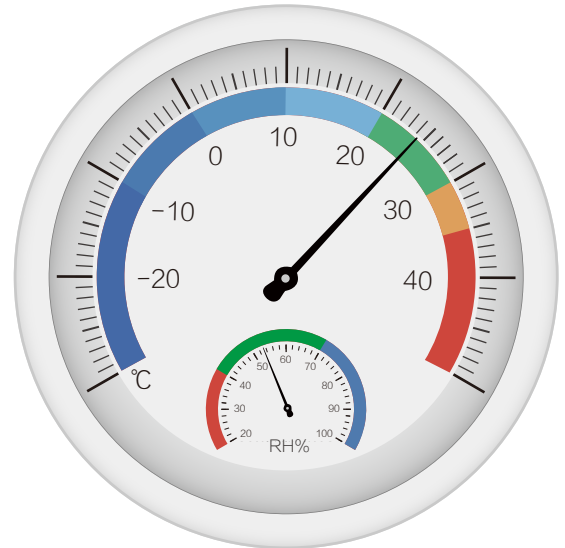

- Boiling sterilization: Disinfection and sterilization is through boiling water in the humidity generator. This humidification system is designed in accordance with earth gravity theory, so that water residue inside the generator could be avoid to get rid of bacteria breeding and contamination.
- Water container: Using heat-resisting material, with characteristics of corrosion preventive and long service life, adapt up to 134°C high temperature steam sterilization.
- Inner box wind speed control: $\leq 0.1\text{m/min}$, reduce the surface water loss of infants, lower the inner box noises and create a more quiet and comfortable environment.

Oxygen concentration control technology

- Servo Oxygen Supply: According to air-O₂ distribution standard and O₂ concentration adjustment, B3 infant incubator provides advanced close-loop feedback technology.
- One-press O₂ concentration calibration : Thanks to Comen patented technology—two-point calibration (21 % and 100%), O₂ concentration detection precision reaches to $\pm 2\%$, higher than other brands.

Material

- The transparent shelf is made of food-level Perspex materials with high transparency, safety, and environmental friendly characteristics.
- The bed adopted nature color and environmental friendly ABS materials, more safe and more reliable, improving confort.



Rolling castor from STEINCO with 86 years experiences in this industry. It is the provider of world famous manufacture such as Mercedes Benz, BMW.



Traditional visiting :

Parents have to wait for long time to see their baby in the Department.



Remote Visiting System:

B3 support remote visiting function, parents can see their baby through an APP on their PC, handset/lpad.



Spot Check System:

Doctors could turn on/off observation function freely, and it also has video clip, video playback functions to retain valuable evidences and cases.

Ingenuity Serves for Benevolence, All for Love

Ingenuity is shining at every part of its body. Thinking in a way that healthcare providers think, to help healthcare provider to reduce their workload, to improve the effectiveness of their treatment, to avoid operational risks, is the mission of us.



Human-Machine interaction

8 inches LED touch-screen, key board with backlit and touch operation,
Screen angel adjustable, easy for observation.

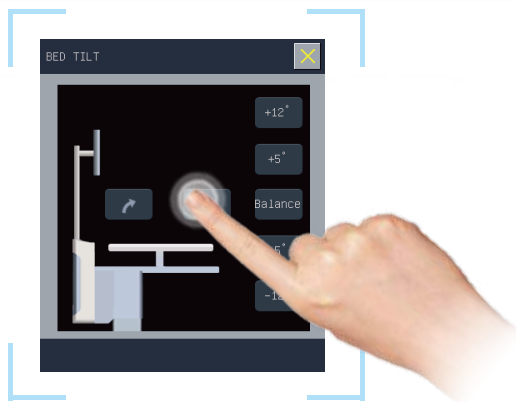

Intelligent Adjustment

Bed tilted angle support maximum 13° , touch screen control, intuitive operation.
Support one press “flat, 5° , 12° ” angel adjustment, to realize instant operation, saving time for clinical emergency, and nursing operation.



Give Wings to the Parents Love



Worrying with anxiety, exhortation with care, looking with impatience, and leaving with reluctance are commonly seen outside of patient rooms. The best wishes of parents are stay 24 hours a day with their child. In order to avoid bacterial contamination, and to prevent frequent interruption of doctors' work, doctors have to implement the traditional visit system. COMEN builds a bridge between babies and parents with love, to alleviate their tension and anxiety, to realize real-time observation even away from the baby.



Unarmed disassemble of beds and sink to realize through cleaning and disinfection. The air circulation system can be thoroughly cleaned without removing the temperature control system and the heating equipment.

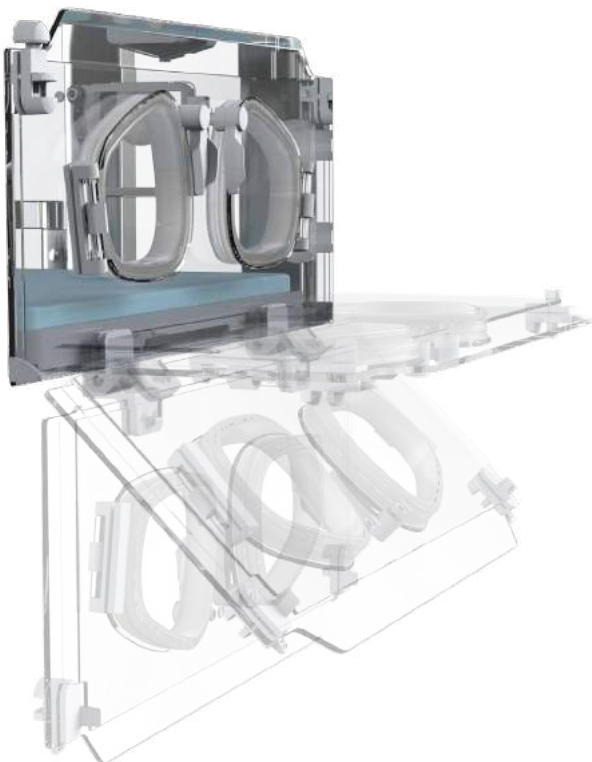

Damping design of the door

Adopting damping design on the left and right access panel, easy to open and close. slowly falling of the panel is able to get rid of hitting the incubator, creating a calm zone around the neonates.

Four independent CPU

Four independent CPU system, these are human-machine interaction, alarm system, temperature collection and thermoregulation, each system works independently without interference to each other, when one CPU fails, it won't affect other CPU systems.

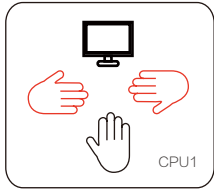

Human-machine interaction



Alarm system

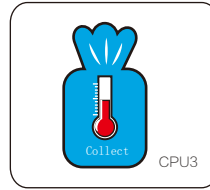

Temperature collection

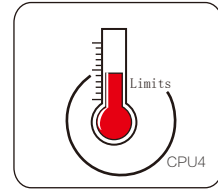

Thermoregulation

Patient Case Management

Built-in 50mm thermal recorder, information such as vital parameters and incubator environment could be recorded.

Wards rounding / Remote Visiting System:

B3 support remote visiting and wards rounding function through internet with an APP on PC, handset / Ipad.

APP



Wired/wireless central monitoring system, automatic save and record infants' vital parameter and incubator parameters.



Configuration

Configuration \ Model	B3 Infant Incubator	B8 Infant Incubator
Infant temperature	√	√
Temperature in incubator	√	√
Weight measurement	▲	▲
ECG(ST analysis)		
NIBP		
RESP	×	√
SpO ₂		
PR		
Damping door	√	√
USB upgrade	√	√
EtCO ₂	×	▲
O ₂ concentration		
Apnea monitoring		
Apnea Self-saving monitoring	▲	▲
Servo O ₂ supply		
Up-lifting	×	√
Camera	▲	▲
Recorder	×	▲
Screen	8" color LED touch screen Resolution: 800×600	12.1" color LED touch screen Resolution: 800×600
Dimension	113cm (L) × 65cm (W) × 135cm (H)	113cm (L) × 68cm (W) × 160cm (H)
Weight	100KG	120KG
Control mode	Air mode, Infant mode	
>37℃	Control through >37℃ button and screen interface	
Air fluid	<0.2m/s	
Bed tilt	Electrical contineous adjusting	
Power supply	100-250V~ 50/60Hz 6.6A	
Battery	2200mAh 14.8V chargeble Li-thium battery, 1 hour contineous working time	

×: Not support

√: Standard

▲: Optional