

KL-602 Syringe Pump

User's Manual



Content

1.	REVISION HISTORY	1
2.	INTRODUCTION.....	2
2.1.	Explanation of symbols	2
2.2.	Features.....	2
2.3.	Declaration.....	2
3.	DESCRIPTION OF PUMP	3
3.1	Product application	3
3.2	Classification	3
3.3	Front view.....	3
3.4	Rear view.....	4
3.5	Syringe view	5
3.6	Power cord.....	5
4.	PRIOR TO PUMP USE	6
4.1.	Warnings	6
4.2.	Precautions.....	7
4.3.	Cleaning and disinfection	7
4.4.	Storage	8
4.5.	Maintenance and repair.....	8
4.6.	Packing list	9
4.7.	Disposal of waste product.....	9
5.	OPERATION	10
5.1.	Check accessories	10
5.2.	Check software version.....	10
5.3.	Default setting.....	10
5.4.	Installation of equipment	11
5.5.	Syringe Installation.....	11
5.6.	Stackable pump.....	13
5.7.	Operating procedures.....	13
5.8.	Pause.....	17
5.9.	Turn off.....	18
5.10.	Mute.....	18
5.11.	Clear infused volume.....	18
5.12.	Memory function	18
5.13.	Run the pump with the built-in battery	18
6.	SPECIAL FUNCTIONS	20
6.1.	Syringe brand.....	20
6.2.	Syringe calibration.....	20
6.3.	Occlusion level	21
6.4.	Bolus.....	21
6.5.	KVO rate.....	21
6.6.	Keyboard lock.....	22

6.7.	LCD backlight	22
6.8.	Time	22
6.9.	Update database	22
6.10.	Language	23
6.11.	Default setting	23
7.	ALARM	24
7.1	Alarm classification	24
7.2	Alarm condition	24
7.3	Alarm sound parameters	24
7.4	Delay of alarms	24
7.5	Trouble shooting	25
8.	SPECIFICATIONS	26
9.	SYMBOLS	28
10.	EMC DECLARATION	29
11.	WARRANTY	33
Appendix A	Chart of flow rate vs time	34
Appendix B	Bolus, duration, pressure value	36

1. REVISION HISTORY

The following revision history table summarizes changes contained in this document.

The right is reserved to change or discontinue this product without notice.

Revision No.	Revision Date	Description of Revisions
1.0	2010/01/08	Initial version.
1.1	2010/05/05	Add syringe brand list.
1.2	2010/11/08	Add VTBI at flow rate settings.
1.3	2011/03/15	Add contents in 4.1 warning.
1.4	2014/09/19	Add "Altitude". Update European representative.
1.5	2015/04/30	Update pictures of front cover, front view and rear view.
1.6	2017/08/18	Update "Chapter 8, syringe brand".

NOTE

Please read this User's Manual before operating the Syringe Pump.

2. INTRODUCTION

2.1. Explanation of symbols



Warning is used to indicate the presence of a hazard which can cause severe personal injury, death or substantial property damage if the warning is ignored.



Caution is used to indicate the presence of a hazard which will cause minor personal injury or property damage if the warning is ignored.

NOTE

Note is used to notify the user of installation, operation or maintenance information which is important but not hazard-related.

2.2. Features

- Compact in design, light in weight and small in size.
- simple and easy to use
- Low running noise.
- 3 working modes.
- Built-in 10 brands of syringe data, convenient for choosing syringes.
- User can define 2 syringes' data into the pump.
- Anti-Bolus function.
- Audio-visual alarms for added safety.
- Display critical clinical dates simultaneously.
- The pump enters KVO (KEEP VEIN OPEN) mode automatically once injection of VTBI is finished.
- The flow rate can be set in 0.1mL/h increments for added accurate.
- 2 ways to input data by keyboard or SHUTTLE key.

2.3. Declaration

Thank you for choosing our Syringe Pump.

In order to use this pump correctly and safely, read this manual carefully before operating the pump. If you have any questions when reading through this manual, please call the local authorized dealer in your country. Retain this manual together with the pump for future reference.

3. DESCRIPTION OF PUMP

3.1 Product application

This Syringe Pump is particularly used in long time and accurate injection. It can be widely used in clinical treatment such as conventional intravenous injection, anesthetic injection, anticoagulant drugs for cancer patients' chemotherapy.

Intended use: The syringe pump is applied to patient by medical institution on intravenous injection administration of drugs and solution.



Contraindication: This pump is fixed rate micro volume injection equipment.
Not for intermittent or variable rate injection.

3.2 Classification

Class II / Internal power supply / Type CF

3.3 Front view

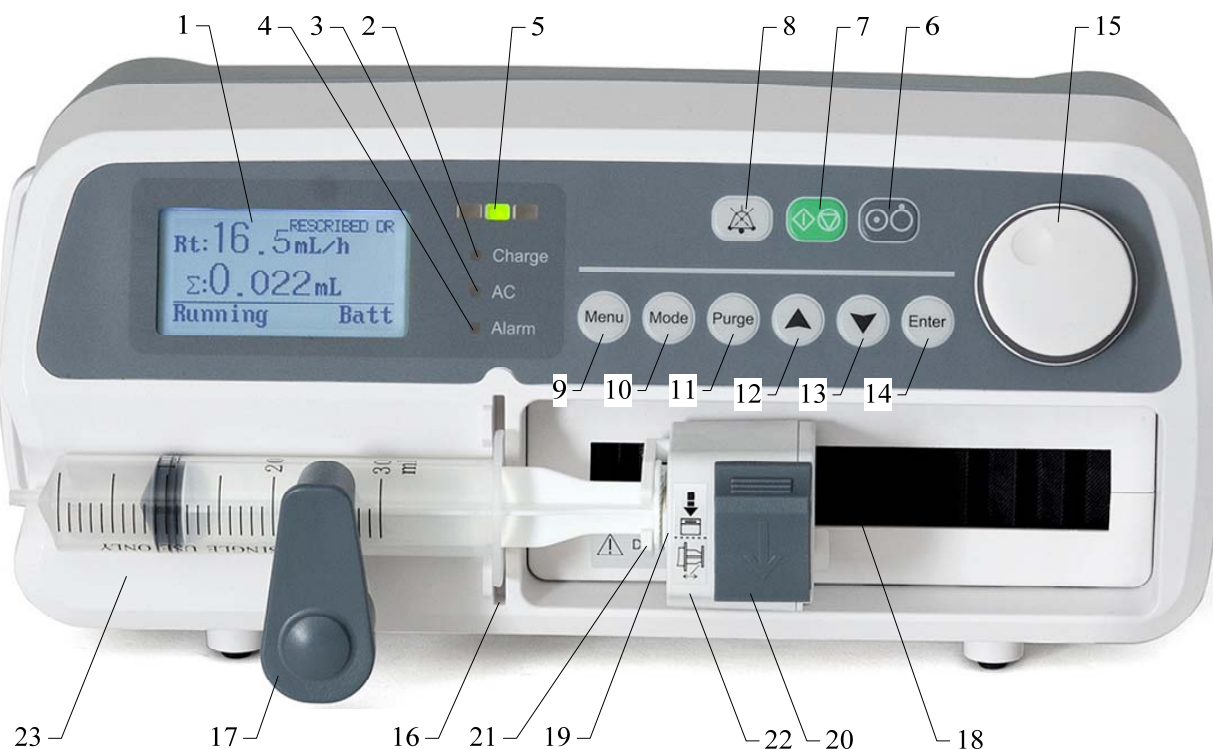

Figure 3.1 Front view

1. LCD DISPLAY: Display settings, accumulation etc.
2. CHARGE LED: Flicking indicates battery under charging.
3. AC LED: Pump powered by alternate current.
4. ALARM LED: Flicking when pump in alarm conditions.
5. WORKING LED: Alternate flash during injection period.
6. [ON/OFF] KEY: Turn on /Turn off the pump.
7. [START/STOP] KEY: Start or stop injection.

8. [MUTE] KEY: Suspend alarm sound.
9. [MENU] KEY: Press to enter menu for watch or change dates.
10. [MODE] KEY: Press to select the infusion mode.
11. [PURGE] KEY: Press to fill liquid in line, bolus control when injection.
12. [INCR] KEY: Choose a menu, or increase the input data.
13. [DECR] KEY: Choose menu, or decrease the input data.
14. [ENTER] KEY: Confirm to choose the menu item or confirm input data.
15. [SHUTTLE] KEY: Rotate cw or ccw to change data or selection of menu items. Press to confirm selection.
16. SYRINGE INSTALL SLOT: To install syringe.
17. SYRINGE PLATE: For fastening syringe and detecting of syringe diameter.
18. WATERPROOF CLOTH: Prevent the liquid from splashing into the pump.
19. PRESSURE SENSOR
20. OPEN NUT: Press it downward to slide syringe pusher manually.
21. PLUNGER HOOK
22. PUSHER
23. V SHAPE SLOT

3.4 Rear view

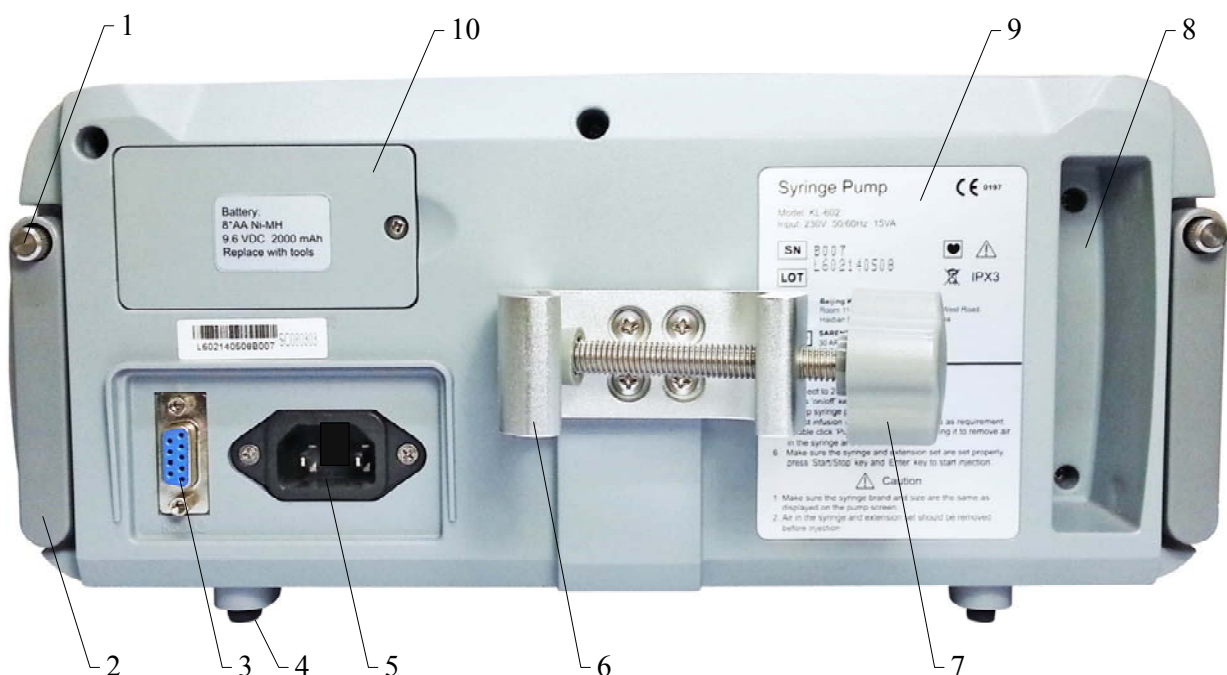
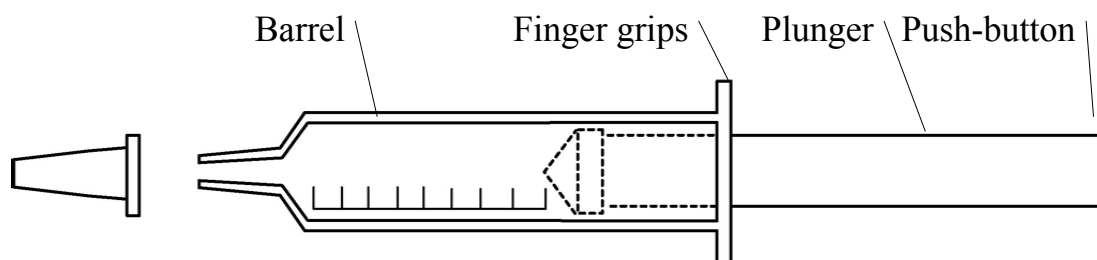

Figure 3.2 Rear view

1. STACKING SHAFT SCREW

2. STACKING SHAFT: Stack single channel pump to multiple channels.
3. COMMUNICATION PORT
4. PUMP FOOT
5. AC POWER INLET
6. POLE CLAMP
7. POLE CLAMP BOLT
8. PUMP HANDLE
9. LABEL
10. BATTERY COVER

3.5 Syringe view



3.6 Power cord



AC power cord

4. PRIOR TO PUMP USE

4.1. Warnings

- This equipment must be used by professional medical related person, such as doctors, nurses and medical appliances experts.
- Pump does self checking when powered on. Always watch information showing on LCD, Make sure all parts are in normal condition.
- Checking and confirming the normal operation of the pump periodically. Check the residual liquid and the syringe conditions. Don't just rely on the pump alarm system.
- If this pump is used in the vicinity of the surgical operation equipment which generates a high frequency current such as mobile phone, radio, or defibrillator, the pump may malfunction because of electrical interference. Please carefully check for any sources of electrical interference in the vicinity before use.
- When using the pump concurrently with the surgical operation equipment, please note the following:
 - Do not use the pump together with any surgical operation equipment that generates high noise level.
 - Be sure that the pump is kept a sufficient distance from the surgical operation equipment
 - The pump and such device should not be powered from the same outlet
 - Check and confirm the normal operation of the pump periodically



In case of malfunction, turn off the power immediately, and remove syringe from the patients. After this action, please contact your local authorized dealer.

- Avoid using the pump in presence of flammable gases and flammable anesthetic mixture with air, oxygen or nitrous oxide.
- The use of any mobile phone very close to the pump is not allowed since the high frequency noise during the conversation could cause malfunction of the pump.
- The use of the pump in MRI rooms such as high-pressure rooms or places where high electromagnetic radiation is generated is not allowed.
- During injection, the range of pump position shall not exceed $\pm 65\text{cm}$ (based on the position of patients' heart)
- No air bubble alarm in the pump, so please make sure there is no air in the syringe in advance.
- Ensure the injection line in proper position before injection.
- The pressure in the syringe rise, when blocked. In this case, if make the line unblocked directly, undesirable quantity of liquid will inject to patient in short time. So some necessary action shall be done properly, like clamp the line before making the line unblocked.
- Before injection, make sure the brand showed on LCD is same as the syringe used. Otherwise, injection accuracy can not be guaranteed.
- Avoid using the pump when any alarm is present.
- Avoid using disposable syringe repeat, or resterilize the syringe before use. After injection, please handle the syringe properly
- Once a patient need to be infused by both gravity infusion and Syringe Pump. Please kindly refer to the following figures:

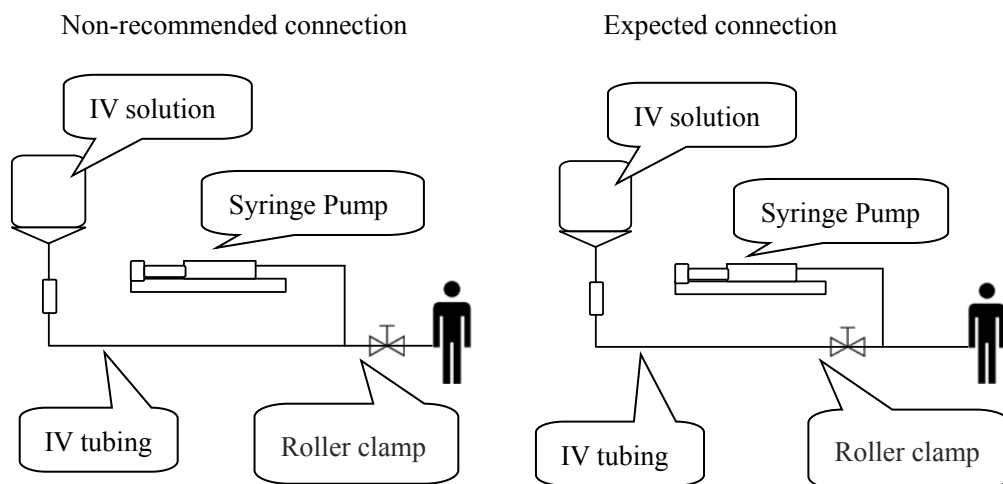

4.2. Precautions

- Please use fingers to operate this pump. Any sharp tool may damage the panel of pump.
- If pump must powered by DC, make sure the battery is not exhaust. If necessary, please recharge it.
- If pump not used for a period of time (over one month), or the power of battery is very low, please recharge the battery by connecting to AC power supply. If the effective time reduce obviously after being charged, it show battery reach the end of life. Please contact authorized dealer to replace it.
- When powered by AC, make sure to use the power cord.
- In case the pump does not work as the user’s manual and can’t find the reason. Please stop the operation and report the details of the problem, including the syringe, flow rate set, series No., infusion mode etc. to the distributor you bought the pump from.
- In order to ensure the connection of injection line is stable, it is better to use mechanical syringe or spiral syringe

4.3. Cleaning and disinfection

Before cleaning the pump, make sure to power off the pump and disconnect the AC power cord. Do not immerse the pump in any liquid nor allow any liquid to leak into the pump. If spillage into the pump mechanism occurs, clean immediately by wiping with a soft cloth.



Do not use drier to dry the unit.

Used pumps should be disinfected before use on another patient.

Do not clean, disinfect or sterilize any part of the pump by autoclaving or with ethylene oxide gas. Doing so may damage the pump and void the warranty.

Do not use the following chemicals on the pump, as they will damage the front panel.

Acetone, ammonia, benzene, hydroxytoluene, methylene chloride, nalkyl dimethyl ethylbenzyl ammonium chloride, and ozone.



If cleansers or disinfectant solutions used, Follow manufacturers' dilution instructions for concentrated cleansers or disinfectant solutions.

Lists 4.1 recommend Cleanser

- A solution of 10% bleach and water
- Soapy water
- Isopropyl alcohol up to 95%
- Distilled water

Lists 4.2 recommend disinfectant solution and Manufacture

Super Edisonite	Edison Chemical Co.
Cleaner	Manufacturer
LpH, Septisol	Vestal Labs
Cidex 7	Surgikos
TOR or Hi-Tor Plus	Huntington Labs
Super Edisonite	Edison Chemical Co.
Bafix	Hysan Corp.

4.4. Storage

Pump should be stored in dry, cool and non-corrosive gases ventilated indoor, long-term storage battery should be full of charge.

Storage temperature: - 20 ~ + 55°C

Relative humidity: ≤93% RH (no condensation)

Atmospheric pressure: 700~1060hPa

NOTE

Avoid the following environment for storage and transport for the Syringe Pump

- Where the unit is exposed to dirt or heavy dust.
- Where the unit is exposed to salty atmosphere.
- Where the unit is exposed to severe vibration or corrosive gas.
- Where the unit is exposed to rough handling.
- Where the unit is exposed to direct sunlight or UV light.
- Where the unit is exposed to water.
- Where the unit is exposed to extreme temperature and humidity.

4.5. Maintenance and repair

Please regular maintenance and maintenance the pump (every six months). If any irregularity and failure are detected, stop operation of the pump immediately and contact your local authorized dealer to repair or replace by supplying the details of the situation.



Never try to disassemble or repair by yourself because it may cause further serious failure.

- Make sure that there is any damage with the pump and components. In case that the unit and components were shocked; do not use them even if visible damages are not observed. Please contact your local authorized dealer.
- Contact your local authorized dealer for periodical inspection of the pump for safety and longer product life.
- Operate the pump with the built-in battery once a month to check its performance the built-in battery is subject to aging. If the operation time is getting short after it is normally recharged, contact your local authorized dealer to replace it. Please be sure that your local authorized dealer checks it annually.
- Please recharge the built-in battery fully for more than 8 hours by connecting the pump to an AC power outlet before the pump is used for the first time or after a long interval.
- If the pump can not powered by AC, it show the fuse built-in pump is out of work. Please contact authorized dealer to repair it.

4.6. Packing list

No.	Description	Qty.
1	Syringe Pump	1
2	Power Cord	1
3	User's Manual	1
4	Certificate	1
5	Syringe	1

4.7. Disposal of waste product

Waste product should be disinfected and sterilized before disposal. After that, please refer to local laws to dispose it.

When battery reaches the end of life, do not throw it into fire or water; do not disassemble, recharge, or short-circuit it. Please refer to local laws to dispose it.

5. OPERATION

5.1. Check accessories

Get the product from the cardboard box, and check content according to the User's Manual 4.6. If not agree, please contact authorized dealer.



Please do not use if the accessories does not comply with packing list.

5.2. Check software version

Follow the steps below to check software version.

- 1) Turn on the Pump.
- 2) Press [MENU] KEY to enter the main menu.

Easy Mode	
Flow Rate	
Time-Based	▼
MENU	Batt

Body Weight	▲
Settings	
MENU	Batt

- 3) Select "Settings" from main menu, press "Enter" key to enter Special Setting menu.

Product Info.	▲
Wireless	
Main Menu	▼
Settings	Batt

- 4) Select "Product Info" from Special Setting menu and press "enter" key to get the information.

Ver. : L602.01.01	
Date : 20091223	
S/N : L602091223A071	
Product	Batt

5.3. Default setting

Default Setting	
Occlusion Level	M (0.05Mpa - 0.10MPa)
Brand of Syringe	KANGJIN
Delay of Backlight	0 (Backlight always on)

Delay of Lock Key	0 (keyboard won't locked)
Bolus	5.0 ml
KVO rate	0.1ml/h
Language	English

NOTE

Users can change settings as required.

5.4. Installation of equipment

Put the pump on the platform of infusion stand, clamp the infusion pole with the pole clamp of the pump, fasten the pole clamp bolt to fix the pump (refer to Figure 5.1).

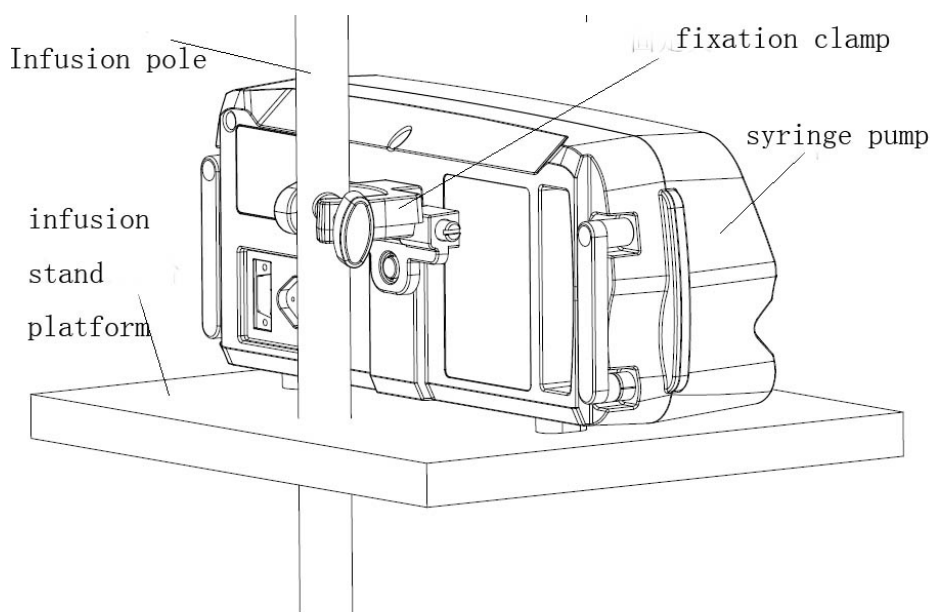

Figure 5.1 Fix the pump on an infusion stand



Fix the pump properly in horizontal direction.

Pump must be put on a stable platform and fixed with the infusion pole.

5.5. Syringe Installation

1. Push down the open nut and slide the pusher to the end of the right.
2. Withdraw and rotate the syringe plate 90 degrees (refer to Figure 5.2).
3. Put the finger grips of the syringe filled with solution with extension line into the syringe install slot. Check the syringe is fitted after the syringe plate is released.

NOTE

If the finger grip of the syringe is not properly placed in the syringe install slot, the flow rate accuracy and alarm system are not guaranteed.

3. Slightly lift plunger of syringe, push down open nut and slide pusher left slowly until it hits push-button of the syringe.

NOTE

Make sure push-button of the syringe must insert to plunger hook. Otherwise, pump may not work properly.

4. Press and hold [PURGE] key to remove air in the syringe and extended line.

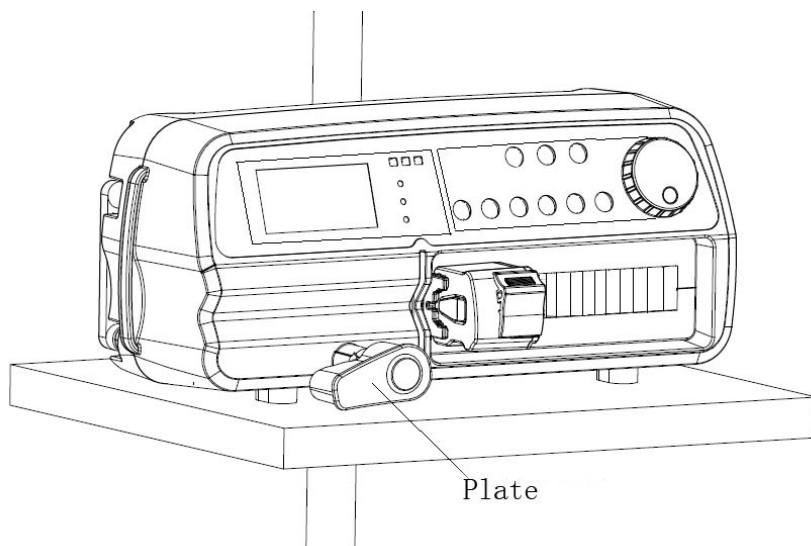

Figure 5.2

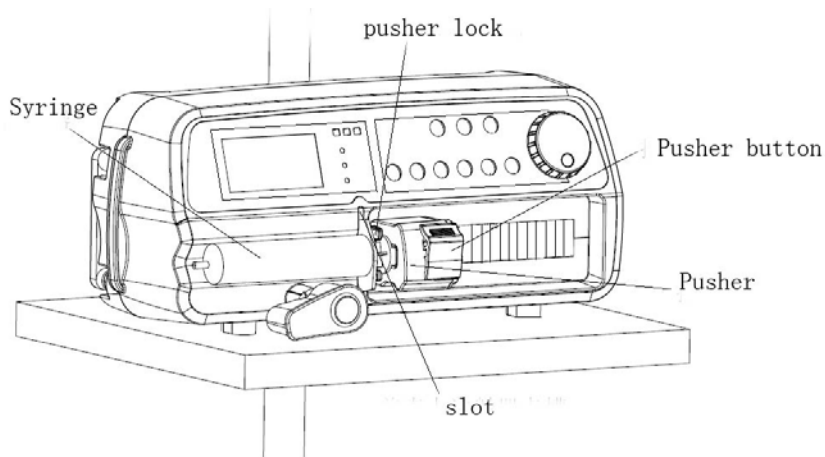

Figure 5.3

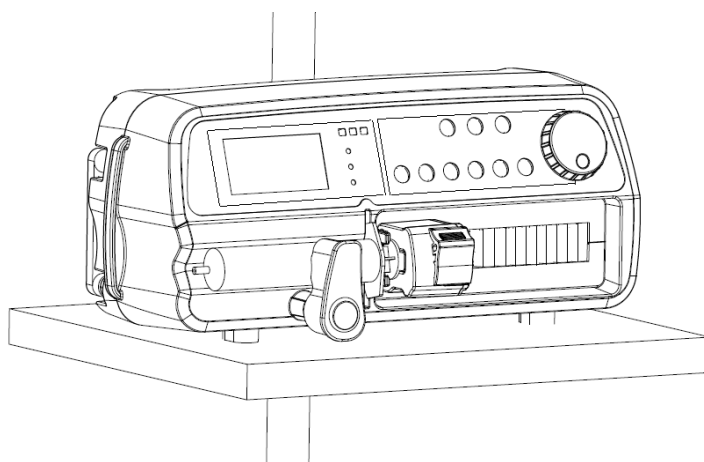

Figure 5.4

5.6. Stackable pump

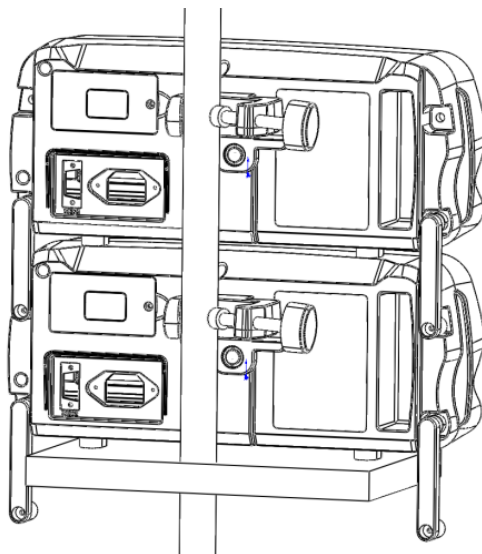

Figure 5.5 Stack the pumps

5.7. Operating procedures

Step 1 Connect to AC power

Connect the AC power cord provided to the AC power inlet at the back of the pump and to an AC power outlet (refer to Figure 5.6).

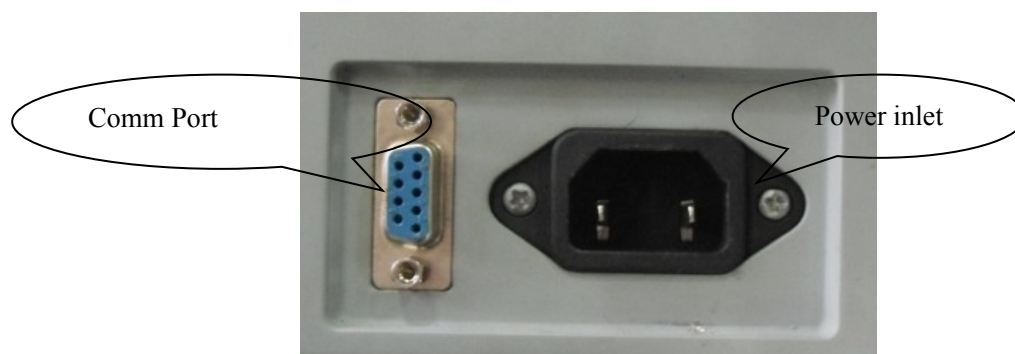

Figure 5.6 Power Socket

Step 2 Turn on

Keep pressing ON/OFF key for over 1s until the logo appear on the display screen

When turning on, the system will enter into self-checking before operation.

It contains:

1. LCD check.
2. Power supply check, DC and AC voltage will display.
3. Pressure check, pressure value display.
4. Syringe recognition check: the current condition of syringe.
5. Keyboard check.

After self-checking, system enter infusion mode.

Step 3 Set infusion mode

After startup, press menu key and enter menu below.

Easy Mode	
Flow Rate	
Time-Based	▼
MENU	AC

Select infusion mode through SHUTTLE key or INCR/DECR key

Press SHUTTLE key or ENTER key to select infusion mode: Flow Rate, Time-based and Body Weight.

1. Flow Rate Mode (ml/h)

Unit	mL/h
Rate	50.0
Vol	-. mL ▼
Rate	Batt

2. Time-Based Mode

Vol	20.0 ml
Time	01 h 00 min
=	20.0 ml/h ▼
Time	Batt

3. Body Weight Mode

Unit	mg/kg/h
Rate	0.01
Conc	0.1 mg/mL ▼
Body Wt	Batt

Conc (Concentration)

Body Wt (Body Weight)

Step 4 Set unit of flow rate

Flow Rate mode.

1) Use MODE key, enter into Flow Rate mode parameters, as follows:

Unit	mL/h
Rate	50.0
Vol	-. mL ▼
Rate	Batt

2) Press ENTER key until select Run item.

Vol	-. mL	▲
=	6.0 mL/h	
Run		Back
Rate		Batt

- 3) Choose the parameter item which need set by rotating SHUTTLE key or INCR/DECR key. Item will reverse display when be focused.

Unit	mL/h	
Rate	50.0	
Vol	-. mL	▼
Rate		Batt

- 4) Press ENTER key or SHUTTLE key to choose the unit item. Unit parameter will reverse display.

Unit	<u>mL/h</u>	
Rate	50.0	
Vol	-. mL	▼
Rate		Batt

- 5) Keep pressing MUTE key, select the unit of flow rate with SHUTTLE key or DECR/INCR key. Press SHUTTLE key or ENTER key to save the unit.

Unit	<u>mL/min</u>	
Rate	50.0	
Vol	-. mL	▼
Rate		Batt

Unit must set in Flow Rate mode and Body Weight mode.

NOTE

Unit at Flow Rate mode: mL/h, mL/min.

Unit at Body Weight mode: mg/kg/h, mg/kg/min, ug/kg/h, ug/kg/min.

Step 5 Set flow rate

- 1) At rate mode use SHUTTLE key or INCR/DECR key to select Rate item and confirm by pressing SHUTTLE key or ENTER key.
- 2) The rate value will reverse displayed

Unit	ml/min	
Rate	<u>5.0</u>	
Vol	-. ml	▼
Rate		Batt

- 3) Rotate SHUTTLE key or press INCR/DECR key to change the value. At the same time the equivalent rate value of ml/h in the next line will vary correspondently.

NOTE

Different type of syringe varies in maximum flow rate, please refer to specification.

Step 6 Set VTBI

- 1) At rate mode use SHUTTLE key or INCR/DECR key to select Vol item and confirm by pressing SHUTTLE key or ENTER key.
- 2) The volume value will reverse displayed

Unit:	ml/min
Rate	5.0
Vol	-.- ml 
Rate	Batt

- 3) Rotate SHUTTLE key or press INCR/DECR key to change the value.

NOTE

If set Vol to -.- ml, it means to inject all liquid in syringe. If set to other value, when this value accomplished, the injection will change to KVO mode automatically.

The volume is limited according to syringes used, refer to list below:

No.	Syringe Size	Maximum Volume
1	10ml	10ml (0.1ml increments)
2	20ml	20ml (0.1ml increments)
3	30ml	30ml (0.1ml increments)
4	50ml	50ml (0.1ml increments)

Parameters also can be set other ways below:

Set VTBI and time

- 1) At Time-Based mode use SHUTTLE key or INCR/DECR key to select Vol item or time item and confirm by pressing SHUTTLE key or ENTER key.
- 2) Change the value and confirm. Equivalent rate value of mL/h in the next line will vary correspondently.

Vol	20.0 mL
Time	01 h 00 min
	= 20.0 ml/h 
Time	Batt

NOTE

Vol limit: 0.1-9999ml. Time limit: 00h01min -99h59min.

Set flow rate, concentration and body weight

- 1) At body weight mode, set rate, concentration and body weight by the same way, as follows:

Unit	mg/kg/min
Rate	0.01
Conc	0.1 mg/mL 
Body Wt	Batt

Conc. (Concentration)

Wt. (Weight)

NOTE

Rate limit: 0.01 – 100.00 Conc. limit: 0.1 - 999mg/ml.

Wt. limit: 1 -300kg.

Step 7 Purge

When injection stops, the pusher will push the plunger of syringe continuously by double pressing and holding the PURGE key. When pump in an injection procedure, it will give a bolus control. Whenever injection stops or not, purging rate is the maximum flow rate. Before injection, use PURGE key to remove air in extension line.

Step 8 Start

- 1) After all injection parameters settled correctly, rotate SHUTTLE key or use INCR/DECR key to select start menu item. Shown as below

Rate 50.0	
= 50.0 ml/h	
Run	Back
Rate	Batt

- 2) Press SHUTTLE key or ENTER key to start, LCD will show below.

Syringe: QIAOPAI	
50ml Scal: 78.2mm	
Enter	Cancel
Rate	Batt

- 3) Check the syringe brand and size, if correct, press SHUTTLE key or ENTER key to confirm. Pump will run immediately. LCD display as below.

Rt: 6.0 mL/h	QIAOPAI 50mL
Σ: 0.119 mL	
Running	Batt



Before start injection, be sure to check the syringe brand and size shown on LCD. If the data not correct, do not force pump running. It may cause big error.

NOTE

In any working mode, after setting data of injection, use START/STOP then ENTER key can start the injection.

5.8. Pause

When pump is running, pause the injection by pressing START/STOP key

Rt: 6.0 mL/h	QIAOPAI 50mL
Σ : 0.119 mL	
Pausing	Batt

5.9. Turn off

Keep pressing ON/OFF key for over 2s to turn off the pump.

NOTE

Please stop injection before turning off the pump.

5.10. Mute

If pump in alarm condition, press MUTE key to silence the pump. After 2 minutes, if the alarm is not released, the alarm will come again.

5.11. Clear infused volume

In “Pause” status, if the [ENTER] key is being pressed for 2 seconds, infused volume changes to “0”.

Rt: 6.0 mL/h	QIAOPAI 50mL
Σ : 0.119 mL	
Pausing	Batt

Rt: 6.0 mL/h	QIAOPAI 50mL
Σ : 0.000 mL	
Pausing	Batt

5.12. Memory function

After a successful starting of injection operation, the parameters will be stored. These parameters can be used for the next injection without any edit operation and can be kept for 8 years in the internal memory.

5.13. Run the pump with the built-in battery

- 1) The pump switches to the built-in battery and [BAT] LED lights turns yellow without AC power.
- 2) The built-in battery is recharged by connecting the pump to an AC power outlet when pump powered on.
- 3) The battery is recharged regardless of the pump status.
- 4) The pump can be operated continuously on the built-in battery for about 5 hours at 5mL/h.

NOTE

When the battery is new, it should be recharged for more than 10 hours. During charging the battery, [CHAG] LED is flicker. When the battery is fully charged, [CHAG] LED turns off automatically



During injection, if BATT LOW shows on LCD with the alarm sounding, the battery should be recharged by connecting the pump to an AC power outlet without pressing any key, otherwise the pump may stop running because the built-in battery will be depleted in 30 minutes.



When the battery is depleted the pump stops running and alarms without a previous notice.

- The battery is subject to aging. Please have your local authorized dealer check it annually.
- To keep the battery in good condition, recharge it at least once a month even if it is not used for a long time.
- Please confirm if the built-in battery works properly by turning on the pump without connecting to an AC power outlet once a month.
- When the pump is used for the first time, or after a long interval, it is necessary to recharge the battery fully by connecting the pump to an AC power outlet for more than 10 hours.

6. SPECIAL FUNCTIONS

6.1. Syringe brand

Under the syringe selection interface, syringe brand and current syringe type will display. Parameters of 4 types of syringes: 10ml, 20ml, 30ml and 50ml displayed under the syringe brand.

Brand:	JIERUI	
10 mL	56.8 mm	21.0 mm
20 mL	69.8 mm	19.6 mm
30 mL	80.4 mm	19.0 mm
50 mL	75.8 mm	22.8 mm
Syringe	Batt	

Use SHUTTLE key or keyboard to choose the syringe brand.

Brand:	B-D	
10 mL	61.2 mm	16.4 mm
20 mL	70.0 mm	16.4 mm
30 mL	81.0 mm	16.7 mm
50 mL	88.0 mm	17.0 mm
Syringe	Batt	

6.2. Syringe calibration

If syringe brand not in the list, select custom-defined syringes. The pump has 2 custom-defined syringes. Each custom-defined syringe includes 4 types of syringe size: 10ml, 20ml, 30ml, 50ml.

Brand:	CUSTOM 1	
A :	76.0	B: 28.0
Enter	Cancel	
Custom	Batt	

Syringe calibration

Tools: 1. Vernier caliper or ruler. 2. Syringe.

Steps:

- 1) Measure A (length of graduation) and B (length between finger grip and push button) and record.

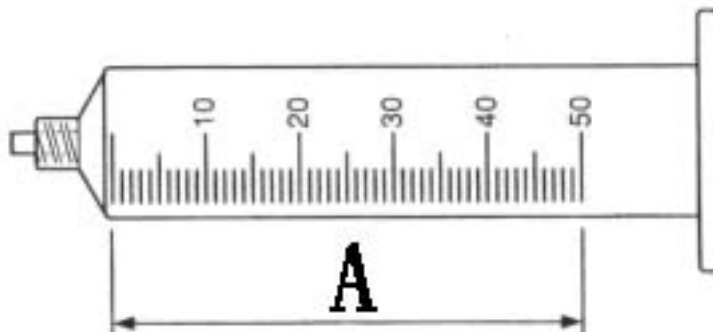

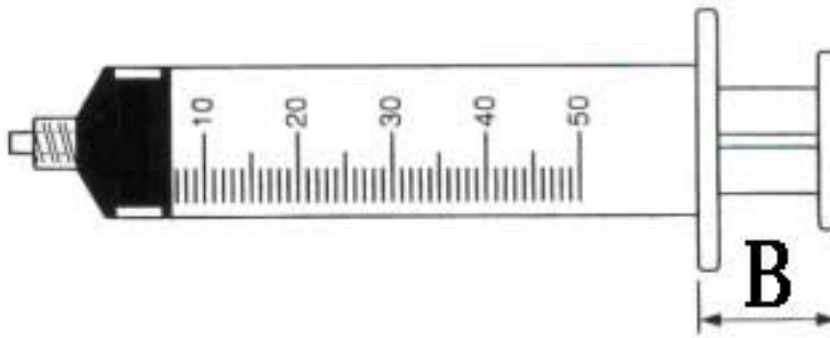

- 2) Install the syringe (for example 10 ml syringe) on the pump.
- 3) Enter interface of syringe calibration.
- 4) Use SHUTTLE key or keyboard to change the brand and data.

Brand:	CUSTOM 1
A: 76.0	B: 28.0
Enter	Cancel
Custom	Batt

- 5) Confirm settings and finish syringe calibration.

NOTE If syringe is not installed correctly, all data won't be stored.

6.3. Occlusion level

The occlusion alarm threshold can be set to low, middle and high. The corresponding pressure value listed below.

H	0.02MPa - 0.07MPa
M	0.05Mpa - 0.10MPa
L	0.08MPa - 0.14MPa

++++L+++++	
Sens	Batt

6.4. Bolus

Bolus means the quantity injected at one time during the operation. The range is: 1.0ml-5.0ml

Bolus: 5.0 mL	
Bolus	Batt

6.5. KVO rate

KVO rate means the rate that can KEEP VEIN OPEN when the injection is completed. The range is

0.1ml/h—1.0ml/h.

KVO: 0.1 ml/h	
KVO	Batt.

6.6. Keyboard lock

Last: 30 Secs	
Lock Key	Batt

NOTE

When set to 00 second, keyboard won't be locked.

6.7. LCD backlight

Last: 30 Secs	
Light	Batt

NOTE

When set to 00 second, the backlight won't be turn off.

6.8. Time

10 – 05 – 12 15: 59: 30	
Enter	
Clock	Batt

Set the time, the time in YY-MM-DD and HH:MM:SS format.\

6.9. Update database

PC Connect...	
Update	Batt

This interface designed for vendor use to update database in pump.

6.10. Language

Lang: English	
Language	Batt

The pump support 2 languages now: simplified Chinese and English.

6.11. Default setting

Confirm	Cancel
Default	Batt

This operation can restore factory settings.

7. ALARM

7.1 Alarm classification

All alarms are technical alarm.

7.2 Alarm condition

Alarms	Priority	Lamp	Description
Occlusion	high	Red 2Hz	When the IV tubing occluded
Syringe off	high	Red 2Hz	Syringe drop off
Nut error	high	Red 2Hz	Nut position is not correct
Speed Error	high	Red 2Hz	Flow rate changed $\pm 30\%$
Low battery	high	Red 2Hz	The battery voltage less than 9.3 V
No power	high	/	Over 30 minutes after the battery voltage less than 9.3 V
Finish	middle	/	Injection finished
Near finish	middle	/	In nearly finished drug injectors inject (surplus 0.5 ml)
No operation	low	/	Pump in standby mode for 2 minutes
AC power off	low	/	The AC power off

7.3 Alarm sound parameters

High priority	
Middle priority	
Low priority	

7.4 Delay of alarms

Alarm	Delay of alarm condition	Delay of alarm signal
Obstruction	30s	200ms
Syringe off	100ms	200ms

Nut error	100ms	200ms
Speed error	10s	200ms
Low battery	1s	200ms
No Power	1s	200ms
Completion	100ms	200ms
Near finish	100ms	200ms
No operation	120s	200ms
AC power off	1s	200ms

7.5 Trouble shooting

Take the following actions if any trouble occurs. When the troubles could not be solved with the following actions, Please contact your local authorized dealer.

Symptom	Cause	Action
Pump cannot be turned on.	AC power cord is not inserted properly	Check AC power cord connection
	Built-in battery is exhaust	Stop the operation of the pump and replace with a new battery through your local authorized dealer
	The voltage of the built-in battery is low.	Recharge the battery fully for more than 8 hours by connecting the pump to an AC power outlet and turn it on
Occlusion alarm	Line folded	Straighten injection loop
	Syringe is not compatible	Change syringe
	Pressure sensor failure	Contact your local authorized dealer
	Syringe not installed correctly	Installed syringe again
Syringe off alarm	Syringe not installed	Install syringe
	Syringe not installed correctly	Installed syringe again
Nut abnormal alarm	Nut position is not correct	Adjust the nut position
Speed abnormal alarm	Battery exhaust	Use the ac power. And replace battery
Low Battery Alarm	The battery voltage is less than 9.3 V	Connect to AC power, recharge the battery
Finish alarm	VTBI is injected	Press [START/STOP] KEY, release the alarm
No operation alarm	Pump in standby mode for 2 minutes	Press any key to release the alarm

8. SPECIFICATIONS

● SYRINGE

FLOW RATE	Syringe 10 ml: 400 ml/h Syringe 20 ml: 600 ml/h Syringe 30 ml: 900 ml/h Syringe 50 ml: 1300 ml/h 0.1 ~ 99.9 mL/h (0.1 ml/h increments) 100 ~ 1300 mL/h (1 ml/h increments)
INJECTION ACCURACY	±2% (mechanical accuracy ≤1%)
INFUSED VOLUME	0.001 ~ 99.999 ml (0.001ml increments) 100.00 ~ 999.99 ml (0.01ml increments) 1000.0 ~ 9999.9 ml (0.1ml increments)
VTBI (volume to be infused)	0.1 ~ 99.9 ml (0.1ml increments) 100 ~ 9999 ml (1ml increments)
KVO RATE	0.1 ~ 1.0 ml/h (0.1 ml/h increments)

● MECHANICAL

PUMPING MECHANISM	screw transmission
DIMENSIONS (W×D×H)	314 (W) ×167 (D) ×140 (H)
WEIGHT	Approximately 2.5kg

● ALARM

ALARMS	Occlusion, near empty, end program, low battery, end battery, AC power off, motor malfunction, system malfunction, reminder alarm, pressure sensor error, syringe installation error, syringe drop off
---------------	--

● FEATURES

SYRINGE SPECIFICATION	10, 20, 30, 50 ml
ANTI-BOLUS	Release pressure when pump get occluded
BOLUS	1.0 ~ 5.0 ml
BOLUS RATE	Syringe 10 ml: 400 ml/h Syringe 20 ml: 600 ml/h Syringe 30 ml: 900 ml/h Syringe 50 ml: 1300 ml/h
Real-time infused volume, automatic power switching, automatic syringe identification, mute key, purge, bolus, anti-bolus, system memory	

● OTHER PARAMETERS

POWER REQUIREMENTS	230V AC, 50Hz 8 * AA NIMH battery 9.6VDC
---------------------------	---















POWER CONSUMPTION	≤ 15VA
CLASSIFICATIONS	Class II / Internal power supply / Type CF
BATTERY OPERATION	Ni-MH / 5 hours (at 5mL/h) / more than 10 hours
BATTERY LIFE	2 years
OPERATION CONDITIONS	5~40°C, 20~90% RH (no condensation)
STORAGE CONDITIONS	-20~55°C, ≤93% RH (no condensation)
WARRANTY PERIOD	1 year
ALTITUDE	2000 meters

● **SYRINGE BRAND**

SYRINGE BRAND	SYRINGE SIZE (ml)
KANGJIN	10, 20, 30, 50 ml
B-D (default setting)	10, 20, 30, 50 ml
B.BRAUN	10, 20, 30, 50 ml
DISPOVAN	10, 20, 50 ml
TERUMO	10, 20, 30, 50 ml
ROMO_JET	10, 20, 50 ml
BIOTECH	10, 20, 30, 50 ml
CUNTOM1	10, 20, 30, 50 ml
CUSTOM2	10, 20, 30, 50 ml

※Specifications and design are subject to change for improvement without prior notice

9. SYMBOLS

Symbol	Description
	Class II
	Caution, consult accompanying documents
	Type CF Equipment (Protection against electrical shock)
IPX3	Waterproof level
	Do not throw it into wastebin
	Consult instructions for use
	AC
	Manufacturer
	Batch code
	Device Serial Number
	vertical upwards
	Keep Dry
	Hand hook is avoid
	Temperature limitation for storage. The highest value is 55°C and the lowest value is -20°C
	Authorized Representative in the European community

10. EMC DECLARATION

The Syringe Pump needs special precautions regarding EMC and needs to be installed and put into service according to the EMC information provided in the accompanying documents;

Portable and mobile RF communications equipment can affect the Syringe Pump.

All cables and maximum length of cables, Transducers and other accessories with which the manufacturer of the Syringe Pump claims compliance with the requirements, Accessories that do not affect compliance with the requirements of these sub clauses need not be listed. Accessories, transducers and cables may be specified either generically or specifically.

NOTE:

Transducers and cables sold by the manufacturer of the Syringe Pump as replacement parts for internal components need not be listed.

The use of accessories, transducers and cables other than those specified, with the exception of transducers and cables sold by the manufacturer of The Syringe Pump as replacement parts for internal components, may result in increased emissions or decreased immunity of The Syringe Pump.

Guidance and manufacturer's declaration – electromagnetic emissions		
The Syringe Pump is intended for use in the electromagnetic environment specified below. The customer or the user of the Syringe Pump should assure that it is used in such an environment.		
Emissions test	Compliance	Electromagnetic environment – guidance
RF emissions CISPR 11	Group 1	The Syringe Pump uses RF energy only for its internal function. Therefore, its RF emissions are very low and are not likely to cause any interference in nearby electronic equipment.
RF emissions CISPR 11	Class A	The Syringe Pump is suitable for use in all establishments other than domestic, and may be used in domestic establishments and those directly connected to the public low-voltage power supply network that supplies buildings used for domestic purposes, provided the following warning is heeded: Warning: This Syringe Pump is intended for use by healthcare professionals only. This equipment/ system may cause radio interference or may disrupt the operation of nearby equipment. It may be necessary to take mitigation measures, such as re-orienting or relocating the Syringe Pump or shielding the location.
Harmonic emissions IEC 61000-3-2	Class A	
Voltage fluctuations/ flicker emissions IEC 61000-3-3	Complies	

Guidance and manufacturer's declaration – electromagnetic immunity			
The Syringe Pump is intended for use in the electromagnetic environment specified below. The customer or the user of the Syringe Pump should assure that it is used in such an environment.			
IMMUNITY test	IEC 60602 test level	Compliance level	Electromagnetic environment – guidance
Electrostatic discharge (ESD) IEC 61000-4-2	± 6 kV contact ± 8 kV air	± 6 kV contact ± 8 kV air	Floors should be wood, concrete or ceramic tile. If floors are covered with synthetic material, the relative

			humidity should be at least 30%.
Electrical fast transient/burst IEC 61000-4-4	± 2 kV for power supply lines ± 1 kV for input/output lines	± 2 kV for power supply lines ± 1 kV for input/output lines	Mains power quality should be that of a typical commercial or hospital environment.
Surge IEC 61000-4-5	± 1 kV line(s) to line(s) ± 2 kV line(s) to earth	± 1 kV line(s) to line(s) ± 2 kV line(s) to earth	Mains power quality should be that of a typical commercial or hospital environment.
Voltage dips, short interruptions and voltage variations on power supply input lines IEC 61000-4-11	<5 % UT (>95 % dip in UT) for 0,5 cycle 40 % UT (60 % dip in UT) for 5 cycles 70 % UT (30 % dip in UT) for 25 cycles <5 % UT (>95 % dip in UT) for 5 s	<5 % UT (>95 % dip in UT) for 0,5 cycle 40 % UT (60 % dip in UT) for 5 cycles 70 % UT (30 % dip in UT) for 25 cycles <5 % UT (>95 % dip in UT) for 5 s	Mains power quality should be that of a typical commercial or hospital environment. If the user of the Syringe Pump requires continued operation during power mains interruptions, it is recommended that the Syringe Pump be powered from an uninterruptible power supply or a battery.
Power frequency (50/60 Hz) magnetic field IEC 61000-4-8	3 A/m	3 A/m	Power frequency magnetic fields should be at levels characteristic of a typical location in a typical commercial or hospital environment.

Guidance and manufacturer's declaration – electromagnetic immunity			
The Syringe Pump is intended for use in the electromagnetic environment specified below. The customer or the user of the Syringe Pump should assure that it is used in such an electromagnetic environment.			
IMMUNITY test	IEC 60602 test level	Compliance level	Electromagnetic environment – guidance
Conducted RF IEC 61000-4-6 Radiated RF IEC 61000-4-3	3 Vrms 150 kHz to 80 MHz 3 V/m 80 MHz to 2,5 GHz	3 Vrms 150 kHz to 80 MHz 3 V/m 80 MHz to 2,5 GHz	Portable and mobile RF communications equipment should be used no closer to any part of the Syringe Pump, including cables, than the recommended separation distance calculated from the equation applicable to the

			<p>frequency of the transmitter.</p> <p>Recommended separation distance</p> $d = 1.17\sqrt{P}$ $d = 1.17\sqrt{P} \quad 80 \text{ MHz to } 800 \text{ MHz}$ $d = 2.33\sqrt{P} \quad 800 \text{ MHz to } 2,5 \text{ GHz}$ <p>where P is the maximum output power rating of the transmitter in watts (W) according to the transmitter manufacturer and d is the recommended separation distance in metres (m).</p> <p>Field strengths from fixed RF transmitters, as determined by an electromagnetic site survey,^a should be less than the compliance level in each frequency range.^b</p> <p>Interference may occur in the vicinity of equipment marked with the following symbol:</p> 
--	--	--	---

NOTE 1 At 80 MHz and 800 MHz, the higher frequency range applies.

NOTE 2 These guidelines may not apply in all situations. Electromagnetic propagation is affected by absorption and reflection from structures, objects and people.

^a Field strengths from fixed transmitters, such as base stations for radio (cellular/cordless) telephones and land mobile radios, amateur radio, AM and FM radio broadcast and TV broadcast cannot be predicted theoretically with accuracy. To assess the electromagnetic environment due to fixed RF transmitters, an electromagnetic site survey should be considered. If the measured field strength in the location in which the Syringe Pump is used exceeds the applicable RF compliance level above, the Syringe Pump should be observed to verify normal operation. If abnormal performance is observed, additional measures may be necessary, such as re-orienting or relocating the Syringe Pump.

^b Over the frequency range 150 kHz to 80 MHz, field strengths should be less than 3 V/m.

Recommended separation distances between portable and mobile RF communications equipment and the Syringe Pump

The Syringe Pump is intended for use in an electromagnetic environment in which radiated RF

disturbances are controlled. The customer or the user of the Syringe Pump can help prevent electromagnetic interference by maintaining a minimum distance between portable and mobile RF communications equipment (transmitters) and the Syringe Pump as recommended below, according to the maximum output power of the communications equipment.			
Rated maximum output power of transmitter W	Separation distance according to frequency of transmitter m		
	150 kHz to 80 MHz $d = 1.17\sqrt{P}$	80 MHz to 800 MHz $d = 1.17\sqrt{P}$	800 MHz to 2,5 GHz $d = 1.17\sqrt{P}$
0.01	0.12	0.12	0.07
0.1	0.37	0.37	0.22
1	1.17	1.17	0.70
10	3.69	3.69	2.21
100	11.67	11.67	7.00
For transmitters rated at a maximum output power not listed above, the recommended separation distance d in metres (m) can be estimated using the equation applicable to the frequency of the transmitter, where P is the maximum output power rating of the transmitter in watts (W) according to the transmitter manufacturer.			
NOTE 1 At 80 MHz and 800 MHz, the separation distance for the higher frequency range applies.			
NOTE 2 These guidelines may not apply in all situations. Electromagnetic propagation is affected by absorption and reflection from structures, objects and people.			

11. WARRANTY

The Syringe Pump has been carefully manufactured from the highest quality components. The pump is guaranteed against defects in material and workmanship for twelve (12) months from date of purchase by the original purchaser.

Manufacturer's obligation, or that of its designated representative under this Warranty, shall be limited, at our option, to repairing or replacing the pump, which upon examination, is found to be defective in material or workmanship. The repair or replacement of any product under this Warranty shall not extend the above mentioned Warranty period.

All repairs under this Warranty should be undertaken only by qualified, trained service personnel. In the event that a pump is found to be defective during the warranty period, the purchaser shall notify manufacturer or its designated representative within thirty (30) days after such defect is discovered.

The defective pump should be sent immediately to manufacturer or its designated representative for inspection, repair or replacement. Material returned should be properly packaged to avoid pump damage.

This Warranty shall not apply to defects or damage caused, wholly or in part, by negligence, spilt fluids, dropping of the pump, misuse, abuse, improper installation or alteration by anyone other than qualified, trained personnel; or to damage resulting from inadequate packaging in returning the pump.

This Warranty is the sole and entire warranty pertaining to manufacturer's products and is in lieu of and excludes all other warranties of any nature whatsoever, whether stated, or implied or arising by operation of law, trade, usage or course of dealing, including but not limited to, warranties of merchantability and warranties of fitness for a particular purpose.

Purchaser expressly agrees that the remedies granted to it under this Warranty are purchaser's sole and exclusive remedies with respect to any claim of purchaser arising under this Warranty.

Appendix A Chart of flow rate vs time

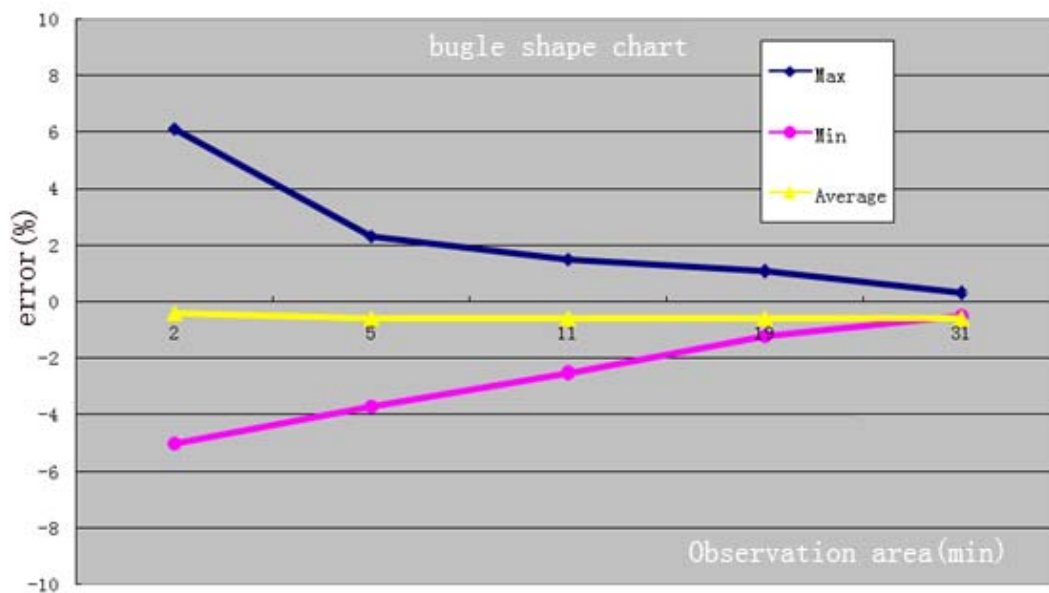

1ml/h bugle shape chart



1ml/h rate chart

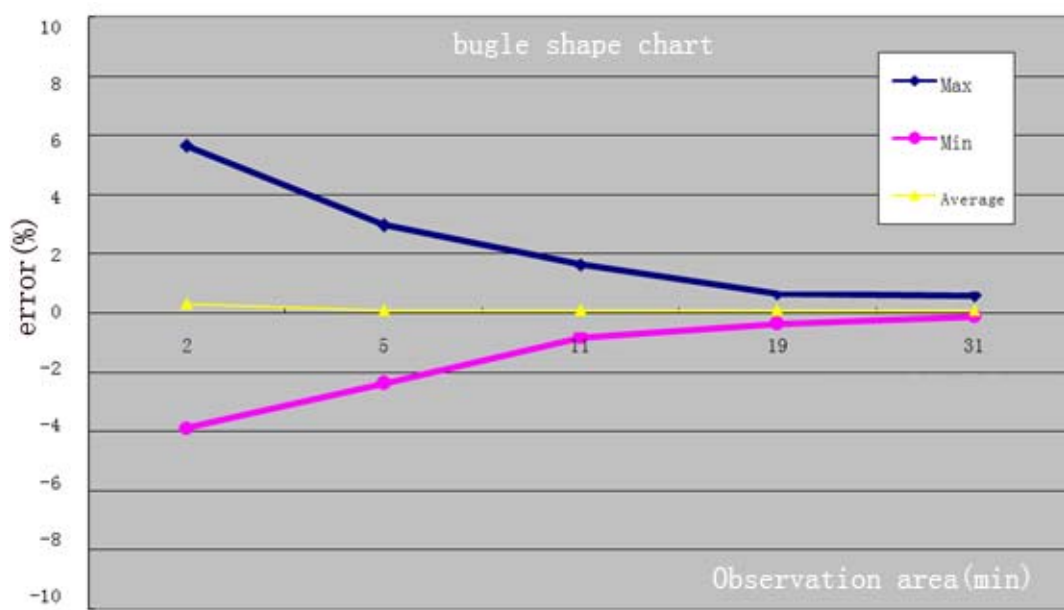

5ml/h bugle shape chart

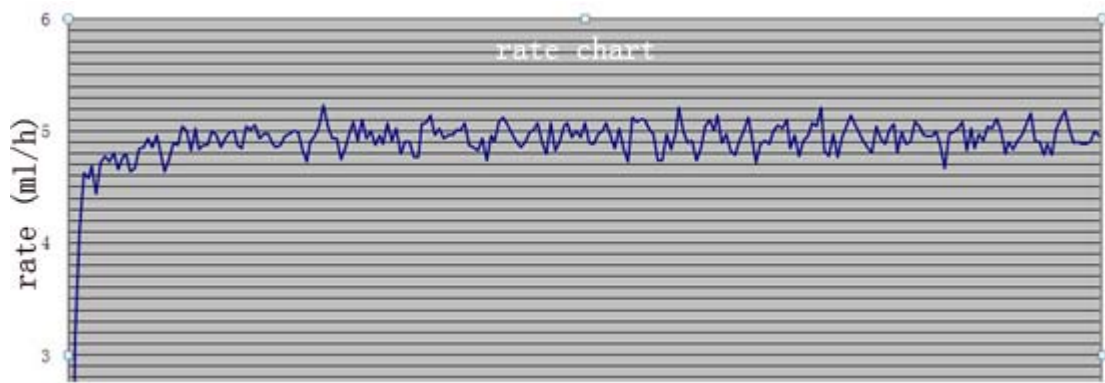

5ml/h rate chart

Appendix B Bolus, duration, pressure value

The duration of giving an alarm, pressure value and bolus value when the tubing occluded.

1. Test condition

Brand of syringe: QIAOPAI

Rate: 5ml/h

2. Record

Syringe	Pressure value	Bolus (g)	Duration (h/m/s)
10ml	H (\cong 0.07MPa)	\cong 0.25	\cong 0/2/27
	M (\cong 0.10MPa)	\cong 0.36	\cong 0/4/15
	L (\cong 0.14MPa)	\cong 0.54	\cong 0/6/27
20ml	H (\cong 0.07MPa)	\cong 0.45	\cong 0/5/01
	M (\cong 0.10MPa)	\cong 0.67	\cong 0/8/11
	L (\cong 0.14MPa)	\cong 1.00	\cong 0/12/10
30ml	H (\cong 0.07MPa)	\cong 0.65	\cong 0/8/40
	M (\cong 0.10MPa)	\cong 1.05	\cong 0/13/07
	L (\cong 0.14MPa)	\cong 1.33	\cong 0/15/53
50ml	H (\cong 0.07MPa)	\cong 1.24	\cong 0/15/33
	M (\cong 0.10MPa)	\cong 1.57	\cong 0/18/47
	L (\cong 0.14MPa)	\cong 2.05	\cong 0/24/40



Beijing KellyMed Co., Ltd.

Room 115, 4 # Building, No. 2 Tiyuan West Road,
Haidian District, Beijing, 100084, China
Tel: +86-10-82490385
Fax: +86-10-65587908



Obelis s.a.

Bd. Général Wahis 53, 1030 Brussels, Belgium
Tel: +(32)2 732 59-54
Fax: +(32)2 732 60-03